

# Math 7

## Module 3 Lines and Shapes

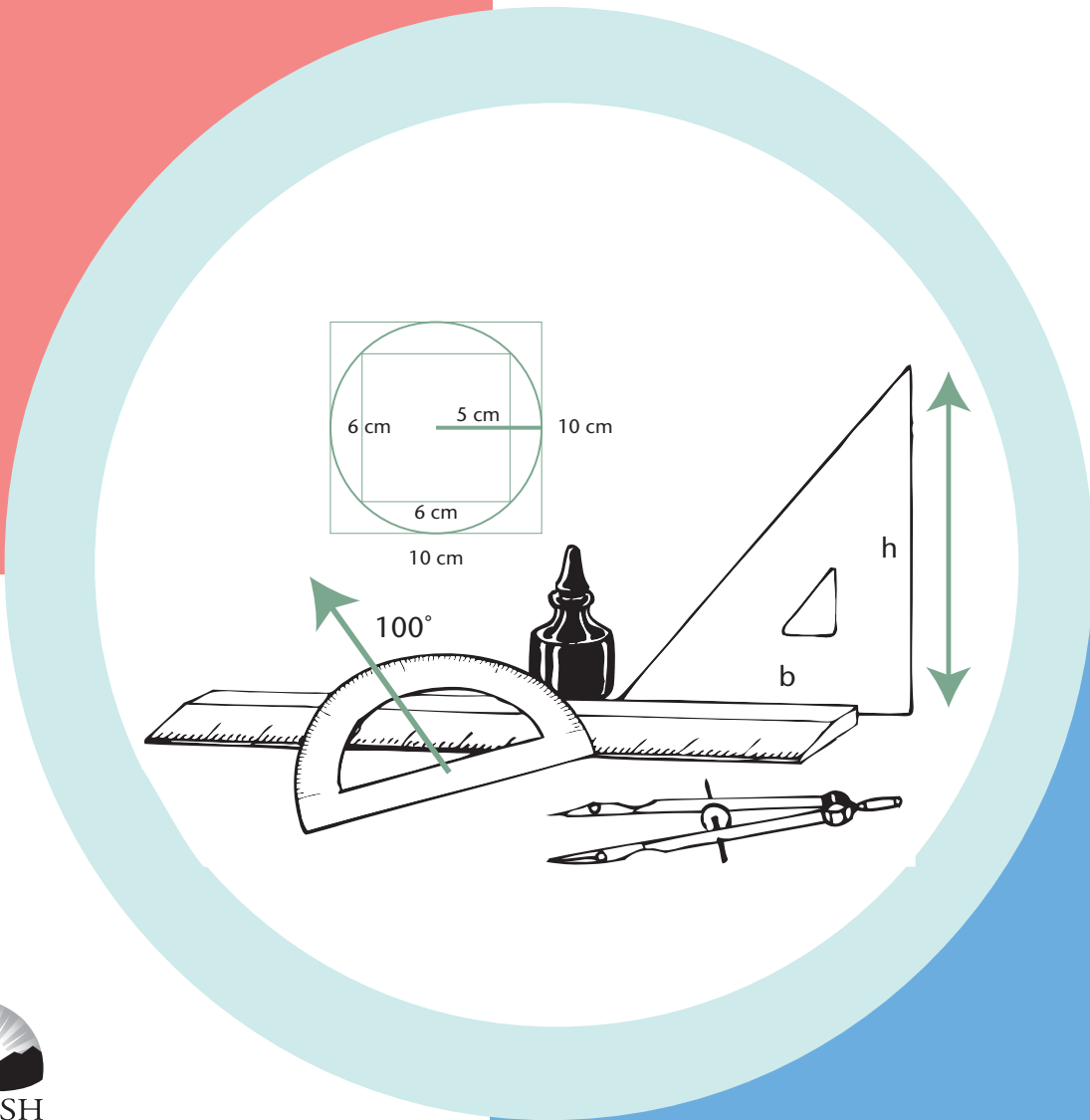

© 2008 by Open School BC

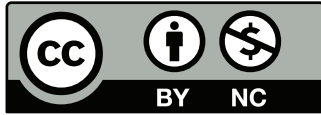

<http://mirrors.creativecommons.org/presskit/buttons/88x31/eps/by-nc.eps>

This work is licensed under the Creative Commons Attribution-NonCommercial 4.0 International License. To view a copy of this license, visit <http://creativecommons.org/licenses/by-nc/4.0/>.

### Course History

New, September 2008

**Project Manager:** Jennifer Riddel

**Project Coordinator:** Eleanor Liddy, Jennifer Riddel

**Planning Team:** Renee Gallant (South Island Distance Education School), Eleanor Liddy (Open School BC), Steve Lott (Vancouver Learning Network), Jennifer Riddel (Open School BC), Mike Sherman, Alan Taylor (Raven Research), Angela Voll (School District 79), Anne Williams (Fraser Valley Distance Education School)

**Writers:** Meghan Canil (Little Flower Academy), Shelley Moore (School District 38), Laurie Petrucci (School District 60), Angela Voll (School District 79)

**Reviewers:** Daniel Laidlaw, Steve Lott (Vancouver Learning Network), Angela Voll (School District 79)

**Editor:** Shannon Mitchell, Leanne Baugh-Peterson

**Production Technician:** Beverly Carstensen, Caitlin Flanders, Sean Owen

**Media Coordinator:** Christine Ramkeesoon

**Graphics:** Cal Jones

# Module 3 Table of Contents

<b>Course Overview</b>	3
<b>Module Overview</b>	8
<b>Section 1: Geometric Constructions</b>	9
Pretest	11
Lesson A: From Points to Lines	17
Lesson B: Tools and Terminology	39
Lesson C: Constructing Perpendicular Bisectors	49
Lesson D: Constructing Angle Bisectors	65
Lesson E: Constructing Parallel Line Segments	77
<b>Section 2: Areas of Polygons</b>	93
Pretest	95
Lesson A: How Do We Measure Things?	99
Lesson B: Finding the Area of Triangles	117
Lesson C: Finding the Area of Parallelograms	131
Lesson D: Problem Solving with Area	145
<b>Section 3: Circles</b>	165
Pretest	167
Lesson A: What's in a Circle?	173
Lesson B: What is Pi?	187
Lesson C: Circumference of a Circle	197
Lesson D: Area of a Circle	211
<b>Templates</b>	229
<b>Answer Key</b>	239
<b>Glossary</b>	265



# Course Overview

## Welcome to Mathematics 7!

In this course you will continue your exploration of mathematics. You'll have a chance to practise and review the math skills you already have as you learn new concepts and skills. This course will focus on math in the world around you and help you to increase your ability to think mathematically.

## Organization of the Course

The Mathematics 7 course is made up of seven modules. These modules are:

Module 1: Numbers and Operations

Module 2: Fractions, Decimals, and Percents

Module 3: Lines and Shapes

Module 4: Cartesian Plane

Module 5: Patterns

Module 6: Equations

Module 7: Statistics and Probability

## Organization of the Modules

Each module has either two or three sections. The sections have the following features:

Pretest	This is for students who feel they already know the concepts in the section. It is divided by lesson, so you can get an idea of where you need to focus your attention within the section.
---------	--

Section Challenge	This is a real-world application of the concepts and skills to be learned in the section. You may want to try the problem at the beginning of the section if you're feeling confident. If you're not sure how to solve the problem right away, don't worry—you'll learn all the skills you need as you complete the lessons. We'll return to the problem at the end of the section.
-------------------	---

Each section is divided into lessons. Each lesson is made up of the following parts:

Student Inquiry	Inquiry questions are based on the concepts in each lesson. This activity will help you organize information and reflect on your learning.
Warm-up	This is a brief drill or review to get ready for the lesson.
Explore	This is the main teaching part of the lesson. Here you will explore new concepts and learn new skills.
Practice	These are activities for you to complete to solidify your new skills. Mark these activities using the answer key at the end of the module.

At the end of each module you will find:

Resources	Templates to pull out, cut, colour, or fold in order to complete specific activities. You will be directed to these as needed.
Glossary	This is a list of key terms and their definitions for the module.
Answer Key	This contains all of the solutions to the Pretests, Warm-ups and Practice activities.

## Thinking Space

The column on the right hand side of the lesson pages is called the Thinking Space. Use this space to interact with the text using the strategies that are outlined in Module 1. Special icons in the Thinking Space will cue you to use specific strategies (see the table below). Remember, you don't have to wait for the cues—you can use this space whenever you want!



Just Think It:  
Questions

Write down questions you have or things you want to come back to.



Just Think It:  
Comments

Write down general comments about patterns or things you notice.



Just Think It:  
Responses

Record your thoughts and ideas or respond to a question in the text.



Sketch It Out

Draw a picture to help you understand the concept or problem.



Word Attack

Identify important words or words that you don't understand.



Making Connections

Connect what you are learning to things you already know.

## More About the Pretest

There is a pretest at the beginning of each section. This pretest has questions for each lesson in the sections. Complete this pretest if you think that you already have a strong grasp of the topics and concepts covered in the section. Mark your answers using the key found at the end of the module.

If you get all the answers correct (100%), you may decide that you can omit the lesson activities.

If you get all the answers correct for one or more lessons, but not for the whole pretest, you can decide whether you can omit the activities for those lessons.

## Materials and Resources

There is no textbook required for this course. All of the necessary materials and exercises are found in the modules.

In some cases, you will be referred to templates to pull out, cut, colour, or fold. These templates will always be found near the end of the module, just in front of the answer key.

You will need a calculator for some of the activities and a geometry set for Module 3 and Module 7.

If you have Internet access, you might want to do some exploring online. The Math 7 Course Website will be a good starting point. Go to <http://www.openschool.bc.ca/courses/math/math7/mod3.htm> and find the lesson that you're working on. You'll find relevant links to websites with games, activities, and extra practice. Note: access to the course website is not required to complete the course.



## Icons

In addition to the thinking space icons, you will see a few icons used on the left-hand side of the page. These icons are used to signal a change in activity or to bring your attention to important instructions.



Explore Online



Warm-up



Explore



Practice



Answer Key



Use a Calculator

## Module 3 Overview

As its title suggests, this module is all about lines and shapes. You'll need to get out your pencil, ruler, protractor, and compass, because this module is truly hands-on!

You'll draw lines, angles, and all kinds of shapes. You may remember, from previous grades, how to calculate the perimeters and areas of some shapes. In this module, you'll review those topics and then learn the skills you need to find the areas of other shapes, like triangles and parallelograms.

Once you've explored polygons, it will be time to move to circles. You'll investigate many of the characteristics of circles and learn about a special number called pi ( $\pi$ )...are you hungry yet?

### Section Overviews

#### Section 3.1: Geometric Constructions

In this first section of Module 3, you will gain a working understanding of lines and angles. You will learn some new terminology, and then it will be time to get out the toolbox! Armed with a protractor and a compass, you'll be performing a number of geometric constructions, all on your own. By the end of this section you'll have all the skills you need to design a tree house!

#### Section 3.2: Areas of Polygons

In this section, you'll build on your knowledge of measurement. You'll discover how to find the area of a triangle and of a parallelogram. Then, applying these new skills, you'll tackle some everyday problems. Put your thinking cap on, these problems might have a few steps... but don't worry, you'll be well prepared to solve them!

#### Section 3.3: Circles

By the time you move on to this third section, you'll be pretty familiar with lines, angles, polygons, and with measuring all of these things. There's one shape left in this module: the circle. In this section you'll investigate the characteristics of circles and discover a special relationship between the parts of a circle. This relationship will help you measure the area of, and the distance around, any circle you meet.

# Section 3.1: Geometric Constructions

## Section

# 1

### Contents at a Glance

Pretest	11
Section Challenge	16
Lesson A: From Points to Lines	17
Lesson B: Tools and Terminology	39
Lesson C: Constructing Perpendicular Bisectors	49
Lesson D: Constructing Angle Bisectors	65
Lesson E: Constructing Parallel Line Segments	77
Section Summary	87

### Learning Outcomes

By the end of this section you will be better able to:

- find examples of parallel line segments and perpendicular line segments in the world around you.
- draw parallel line segments and perpendicular line segments and explain why they are parallel or perpendicular.
- draw a perpendicular bisector and explain what makes it a perpendicular bisector.
- draw an angle bisector and explain how you know it's an angle bisector.



## Pretest 3.1

Complete this pretest if you think that you already have a strong grasp of the topics and concepts covered in this section. Mark your answers using the key found at the end of the module.

If you get all the answers correct (100%), you may decide that you can omit the lesson activities.

- Sort the following groups of lines into parallel or perpendicular lines.

a.

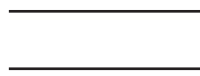

b.

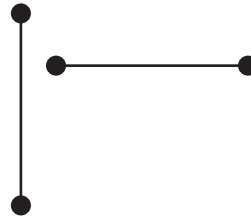

c.

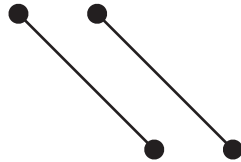

d.

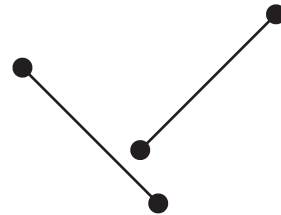

2. Draw a line segment of the length given. Then, use your protractor to draw the angle on the line segment.

a. Line segment = 4 cm, angle =  $45^\circ$

b. Line segment = 3 cm, angle =  $120^\circ$

c. Line segment = 2.5 cm, angle =  $90^\circ$

3. List three examples of perpendicular lines in everyday life.

1.

2.

3.

4. List three examples of parallel lines in everyday life.

1.

2.

3.

5. Fill in the blanks.
- You can use a \_\_\_\_\_ to construct circles and arcs.
  - A \_\_\_\_\_ intersects a line segment at 90 degrees and divides it into two equal lengths.
  - One example of a perpendicular bisector is the letter \_\_\_\_\_.
  - You can use a \_\_\_\_\_ to measure angles.
  - An \_\_\_\_\_ cuts an angle in half to form two equal angles.
6. Draw a perpendicular bisector of a line segment using different construction methods. For each question, draw a line segment that is the length indicated. Then construct the perpendicular bisector using the given construction method.
- 73 mm—compass and straight edge (ruler)

b. 14 cm—protractor and ruler

c. 11 cm—right angle and ruler



7. Use a protractor to construct each angle. Then construct the angle bisector. Use a different method of construction for each angle.

a.  $130^\circ$  angle

b.  $70^\circ$  angle

8. Draw two parallel line segments that are each 5 cm long using the compass and ruler method.

9. Draw a rectangle with length (6 cm) and width (3 cm) using the protractor and ruler method.



Turn to the Answer Key at the end of the Module and mark your answers.

## Section Challenge

Sarah and Tom want you to design a tree house for their backyard. It sounds very exciting and you have lots of ideas. Quickly, you realize that there are many things that you will need to consider. To start, you'll have to choose a suitable tree. You'll also need to know how to draw parallel and perpendicular line segments. The floor of the tree house has to run parallel to the ground so that people can stand up straight. Also, the walls in the tree house have to run perpendicular to the floor, so they won't fall over.

You'll need to design and build a ladder so they can climb up to their tree house. Sarah and Tom's friends also want you to draw a map with an arrow pointing out the direction to the tree house, so they know how to find it.

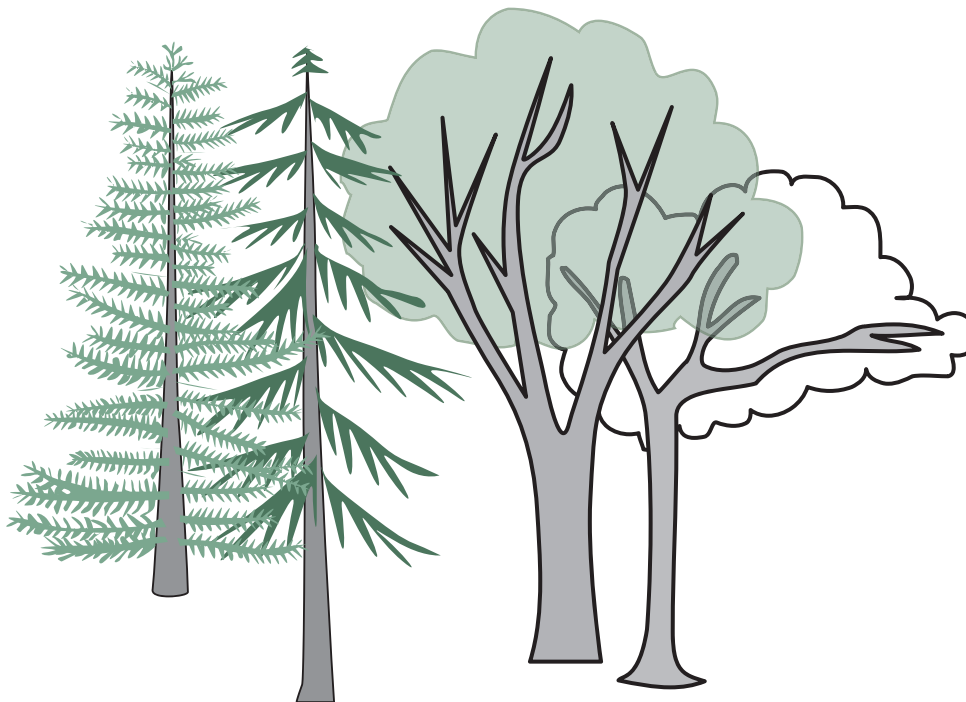

If you're not sure how to solve the problem now, don't worry. You'll learn all the skills you need to solve the problem in this section. Give it a try now, or wait until the end of the section—it's up to you!

## Lesson 3.1A: From Points to Lines

### Student Inquiry



This activity will help you get ready for, learn, and review the information in the upcoming lesson.

When you turn this page over, you will find a chart containing the inquiry outcomes for this lesson. You may be able to answer some of these questions already! Start by writing down your thoughts before the lesson.

When you finish the lesson, answer each question and give an example.

Student Inquiries	BEFORE THE LESSON What I already know about this question:	AFTER THE LESSON What I thought at the end: My final answer, and examples:
What are parallel lines?		answer  example
Can I find an example of parallel line segments in the world around me?		answer  example
What are perpendicular lines?		answer  example
Can I find an example of perpendicular line segments in the world around me?		answer  example

## Lesson 3.1A: From Points to Lines

Thinking Space

### Introduction

A long time ago in Ancient Egypt, a mathematician named Euclid wanted to understand the world around him and prove that things were true by using logic and reason. He did this by studying geometry and the properties of angles, points and straight lines, and shapes such as triangles, squares, and circles.

Euclid wrote books on geometry that have been studied for over 2000 years by math students, artists and architects. Like the Ancient Egyptians, we will begin studying geometry starting with Euclid's observation: *You can draw a straight line between any two points.*

Let's begin!

**Note:** You will need a geometry set to complete the activities in this lesson.



### Explore Online

Looking for more practice or just want to play some fun games?

If you have internet access, go to the Math 7 website at:

<http://www.openschool.bc.ca/courses/math/math7/mod3.html>

Look for *Lesson 3.1A: From Points to Lines* and check out some of the links!



## Warm-up

Let's first review some of the terminology and rules you already know about geometry. Try to fill in the blanks below using the following words:

- parallel
- meet
- perpendicular
- degree
- $^{\circ}$
- right
- protractor
- acute
- obtuse
- 3 o'clock
- zero

1. An angle is formed when two lines \_\_\_\_\_.
2. The unit for measuring angles is the \_\_\_\_\_.
3. \_\_\_\_\_ lines never meet.
4. A protractor has 180 congruent slices. Each slice is 1 degree.  
You write 1 \_\_\_\_\_.
5. At \_\_\_\_\_ the hands of the clock make an angle of 90 degrees.
6. \_\_\_\_\_ lines meet at  $90^{\circ}$ .
7. A  $90^{\circ}$  angle is called a \_\_\_\_\_ angle.

8. The measure of an \_\_\_\_\_ angle is less than  $90^\circ$ .
9. The measure of an \_\_\_\_\_ angle is between  $90^\circ$  and  $180^\circ$ .
10. You use a \_\_\_\_\_ to measure angles.
11. You always read your protector starting from \_\_\_\_\_.
12. Just by looking at these angles, see if you can tell which ones are  $90^\circ$ , which ones are less than  $90^\circ$ , and which ones are greater than  $90^\circ$ .

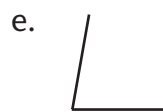
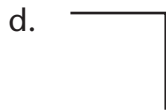
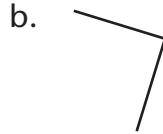

Turn to the Answer Key at the end of the Module and mark your answers.



## Explore How to Use a Protractor

Thinking Space

Here is an illustration of a protractor, a tool that you will find in your geometry set.

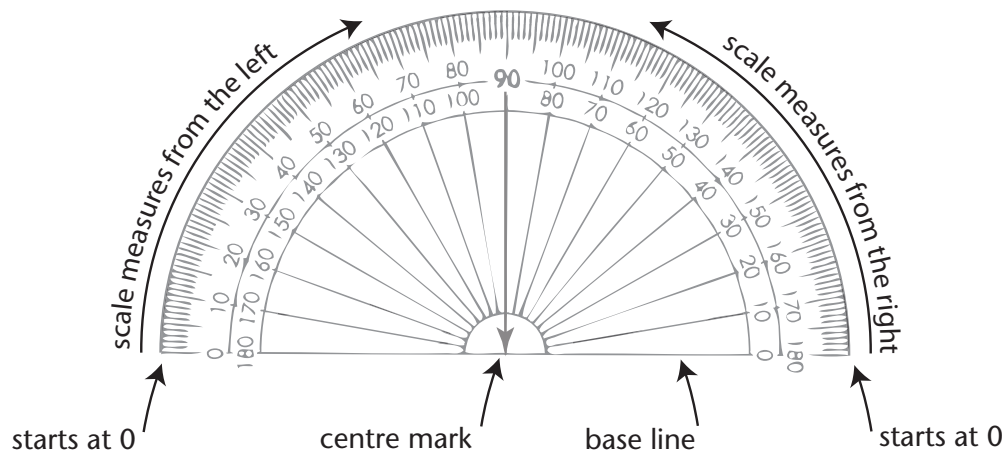

You will see that there are two scales on each protractor. One scale starts at the right. The other scale starts at the left. Both scales are marked from  $0^\circ$  through  $180^\circ$ .

Now let's review how to use the protractor to measure angles.

- Step 1: Place the centre mark of the protractor directly on the vertex of the angle.
- Step 2: Line up one arm of the angle with the base line of the protractor so that it starts at  $0$  degrees.
- Step 3: Use the scale that starts at  $0^\circ$ .
- Step 4: Read the measure of the angle.



**Example 1:**

Look at the protractor shown below. Using the steps on how to use a protractor, you should find that the angle is  $40^\circ$ .

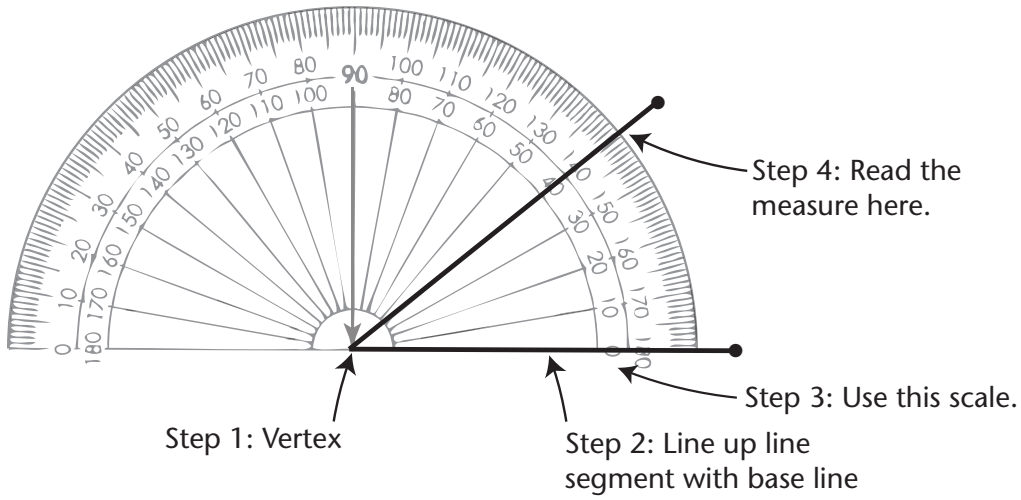

**Example 2:**

Look at the protractor shown below. Using the steps on how to use a protractor, you should find that the angle is  $50^\circ$ .

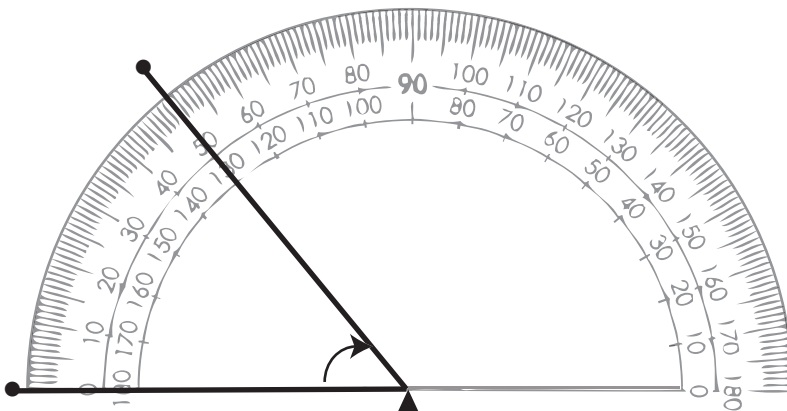

Thinking Space

### Example 3:

Look at the protractor shown below. Using the steps on how to use a protractor, you should find that the angle is  $140^\circ$ .

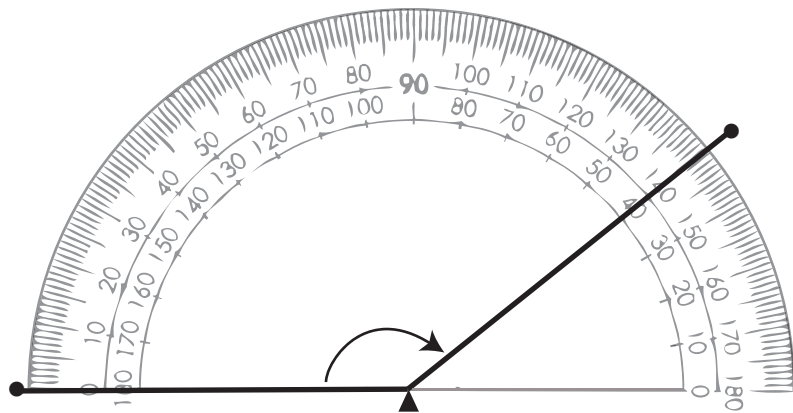

Now it's your turn.

Thinking Space



## Practice 1

1. Read these protractors to give the size of each angle shown.

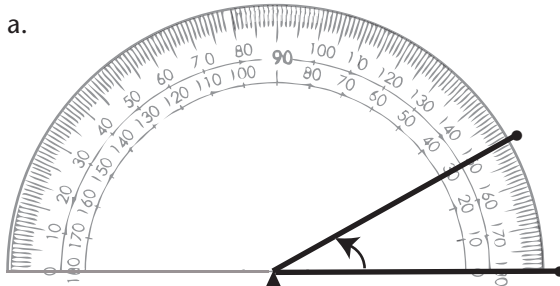

Angle = \_\_\_\_\_

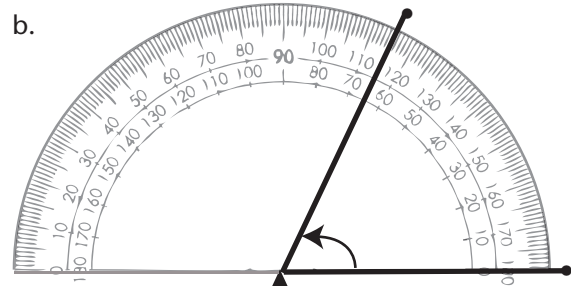

Angle = \_\_\_\_\_

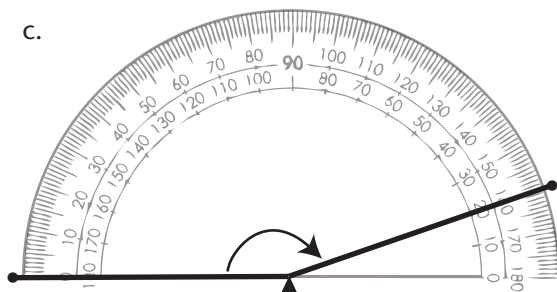

Angle = \_\_\_\_\_

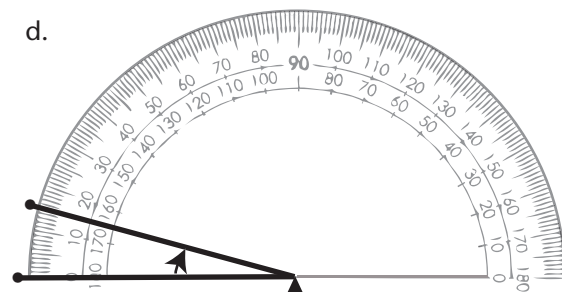

Angle = \_\_\_\_\_

2. Use your protractor to measure these angles

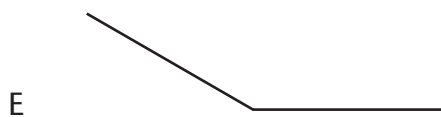
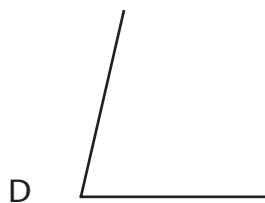
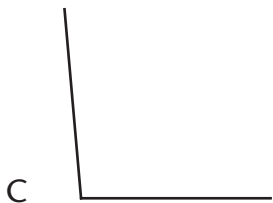
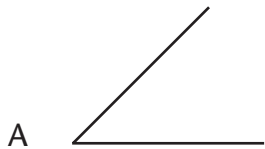

$\angle A =$  \_\_\_\_\_

$\angle B =$  \_\_\_\_\_

$\angle C =$  \_\_\_\_\_

$\angle D =$  \_\_\_\_\_

$\angle E =$  \_\_\_\_\_



Turn to the Answer Key at the end of the Module and mark your answers.



## Explore

Now you are going to learn how to draw your own angles. Remember Euclid's observation: you can draw a straight line between any two points.

### Line Segments, Lines, and Rays

A line segment is a straight line between two points. It has two definite end points and a definite length.  $\overline{AB}$  means "the line segment from A to B".

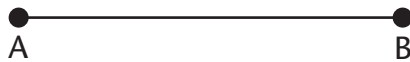

A line is a straight mark. A line is continuous without a beginning or end.



A ray has a beginning point, but no end.

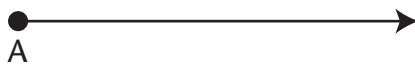

### Thinking Space



What are the differences and similarities among line segments, lines and rays?

# How to Draw an Angle Using a Ruler and Protractor

Here are the steps to follow:

Thinking Space

Step 1: Start with two points.



Step 2: Using your ruler, draw a line between these two points.



Step 3: Place the centre of the protractor on one point of the line segment.

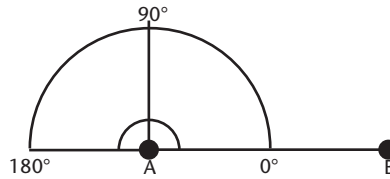

Step 4: Line up the line segment with the base line of the protractor.

Step 5: Start at 0° on the base line.

Step 6: Count around from 0° until you reach the angle you would like to draw.

Step 7: Make a mark with your pencil on the paper.

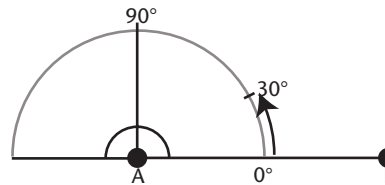

Step 8: Remove the protractor.

Step 9: Draw a line from the point at the centre of the protractor to the mark on your paper.

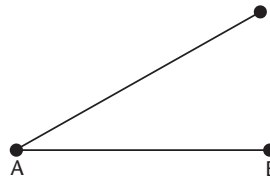

Step 10: Label the measured angle.

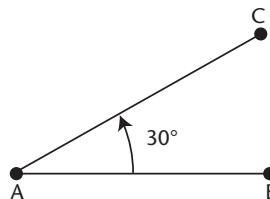

### Draw an Angle with your Protractor

Now it is your turn to draw an angle:

Starting with vertex L on  $\overline{LM}$  draw a  $\overline{LN}$  with an angle of  $60^\circ$  from  $\overline{LM}$ .



Starting with a vertex T on  $\overline{ST}$  draw an angle of  $135^\circ$ .



Thinking Space



Starting with a vertex X on  $\overline{XY}$  draw an angle of  $90^\circ$ .

Thinking Space

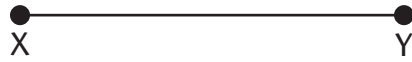

Check to see that your angles match the ones here.

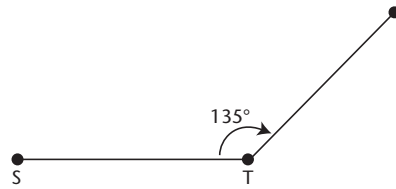
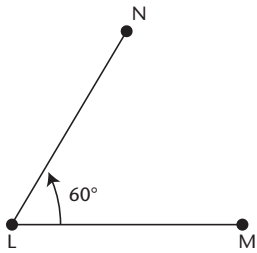



Here's some new terminology relating to intersecting lines.

## Classification of Angles

These are some terms that we use to classify angles by size. You might know some of them already.

### Right Angle

Measures exactly  $90^\circ$  (shown by a small box in the corner.).

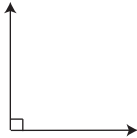

### Acute Angle

Measures less than  $90^\circ$ .

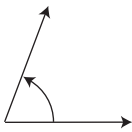

### Obtuse Angle

Measures more than  $90^\circ$  but less than  $180^\circ$ .

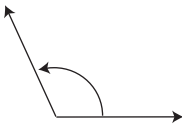

### Straight Angle

Measures exactly  $180^\circ$ .



### Reflex Angle

Measures more than  $180^\circ$  but less than  $360^\circ$ .

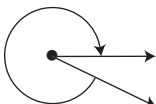

## Parallel and Perpendicular Lines

These two line segments are parallel.

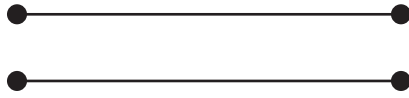

The sides of a ruler are parallel – so are the sides of a ladder. Hopefully, the sides of your house are parallel to each other!

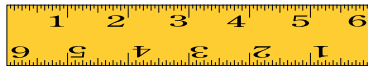

What does parallel mean? **Parallel lines** can be extended forever in both directions and they will never cross.

These lines are parallel.

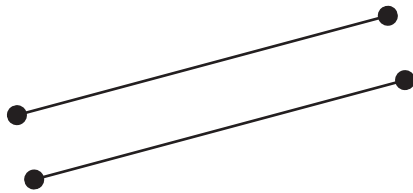

These lines are not parallel. When these lines are extended, they intersect

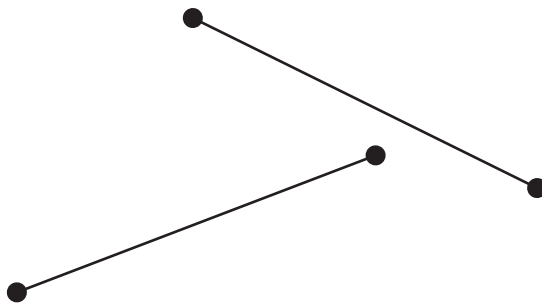

The symbol,  $\parallel$ , means parallel.

$\overline{AB} \parallel \overline{CD}$  means “line AB is parallel to line CD.”

Thinking Space



These two lines are perpendicular.

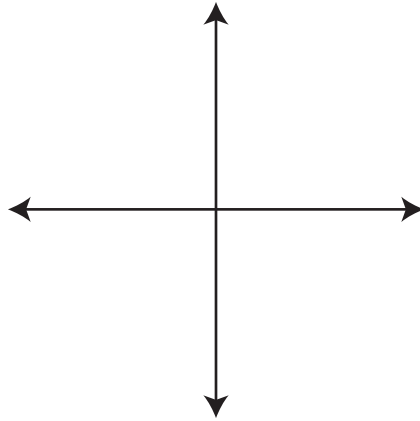

The top of a picture frame is perpendicular to the side. The rungs of a ladder are perpendicular to the sides of the ladder. In your house, the walls are perpendicular to the floor – well, they should be!

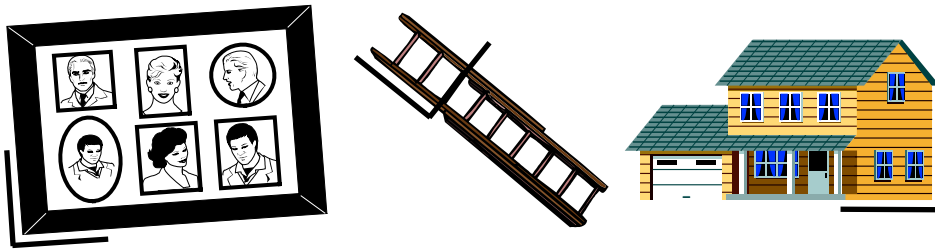

What does perpendicular mean? **Perpendicular lines** meet at right angles.

Check the examples above with your protractor. When you find an angle that is  $90^\circ$ , you can mark it like this:



The symbol shows us that the angle is a right angle; it measures exactly  $90^\circ$ .

Thinking Space



*A right angle is a  $90^\circ$  angle.*

Use your protractor to measure the angles below. Mark the right angles using the symbol.

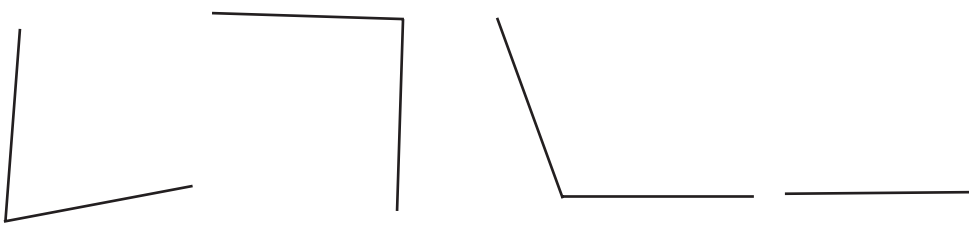

You should have marked the second and fourth angles like this:

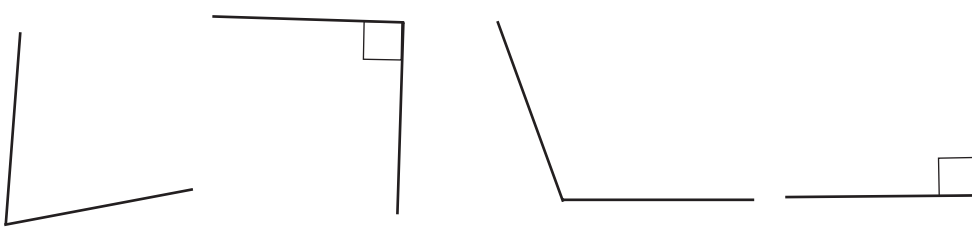

We have another symbol that we use when two lines are perpendicular. It looks like this:  $\perp$ .



$\overline{AB} \perp \overline{CD}$  means "line AB is perpendicular to line CD."

Thinking Space

Here's another one of Euclid's observations: All right angles are equal. If two lines intersect in such a way that they form four congruent angles, they are said to be perpendicular to each other. The angles formed are called right angles ( $90^\circ$ ).

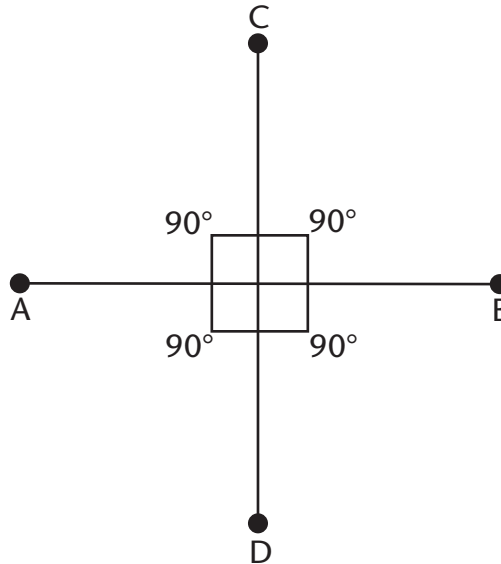
Thinking Space



	SYMBOLS
The symbol for <i>right angle</i> is	
The symbol for <i>perpendicular to</i> is	



## Practice 2

Many things in everyday life remind us of parallel lines and perpendicular lines. The rails of a railroad or the sides of a ruler remind us of parallel lines. The corners of a picture frame or the corners of a room remind us of perpendicular lines.

1. Sort the following groups of lines into parallel or perpendicular lines.

a.

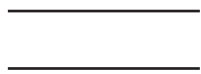

b.

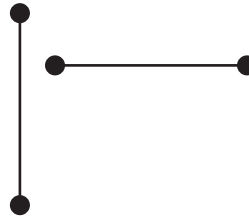

c.

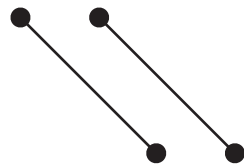

d.

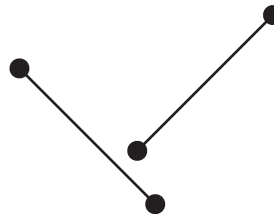

Parallel:

Perpendicular:

2. Use your protractor and check which angles are right angles ( $90^\circ$ ).

a.

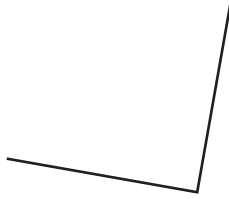

b.

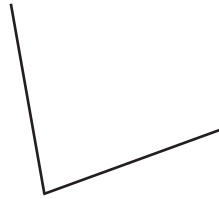

c.

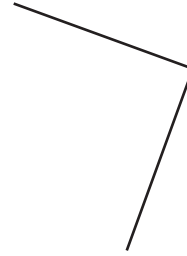

Right angles:

3. Use your protractor to draw the following angles on the given line segment.

a.

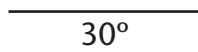

b.

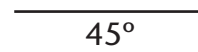

c.

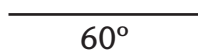

d.

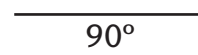

e.

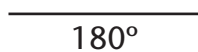

4. List three examples of perpendicular lines in everyday life:

1.

2.

3.

5. List three examples of parallel lines in everyday life:

1.

2.

3.



Turn to the Answer Key at the end of the Module and mark your answers.



## Lesson 3.1B: Tools and Terminology

### Student Inquiry

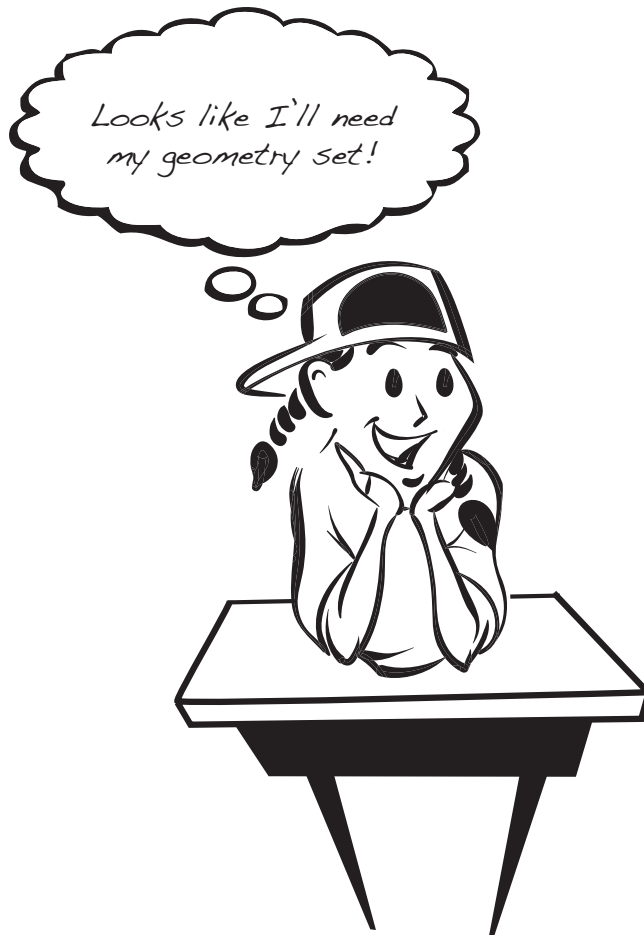

This activity will help you get ready for, learn, and review the information in the upcoming lesson.

When you turn this page over, you will find a chart containing the inquiry outcomes for this lesson. You may be able to answer some of these questions already! Start by writing down your thoughts before the lesson.

When you finish the lesson, answer each question and give an example.

	BEFORE THE LESSON	AFTER THE LESSON
<p>Student Inquiries</p>	<p>What I already know about this question:</p>	<p>What I thought at the end: My final answer, and examples:</p>
<p>What are some examples of perpendicular bisectors in the world around me?</p>		<p>answer</p>
		<p>example</p>
<p>What are some examples of angle bisectors in the world around me?</p>		<p>answer</p>
		<p>example</p>

## Lesson 3.1B: Tools and Terminology

### Introduction

Have you ever wondered how bridges, buildings, railroad tracks, picture frames, soccer fields, or quilts are designed and constructed? Builders all start with similar tools that you can find in your geometry set. In this lesson, we will look at the different tools used in geometry. We will also learn some new words related to geometry. Once you know the definitions, you'll be able to use these words to easily explain the many different lines, angles, and shapes you draw in geometry.



Thinking Space



## Warm-up

Geometry is the study of points, lines, angles, and shapes. What kinds of tools can you use to construct points, lines, angles, and shapes? What are some tools that carpenters and engineers use to construct lines and angles in buildings with?

Using a web, brainstorm some ideas. Start by writing the words geometry tools in the middle of the circle. Think of as many tools as you can. Here's one to start with: What tool do you need to draw a straight line?

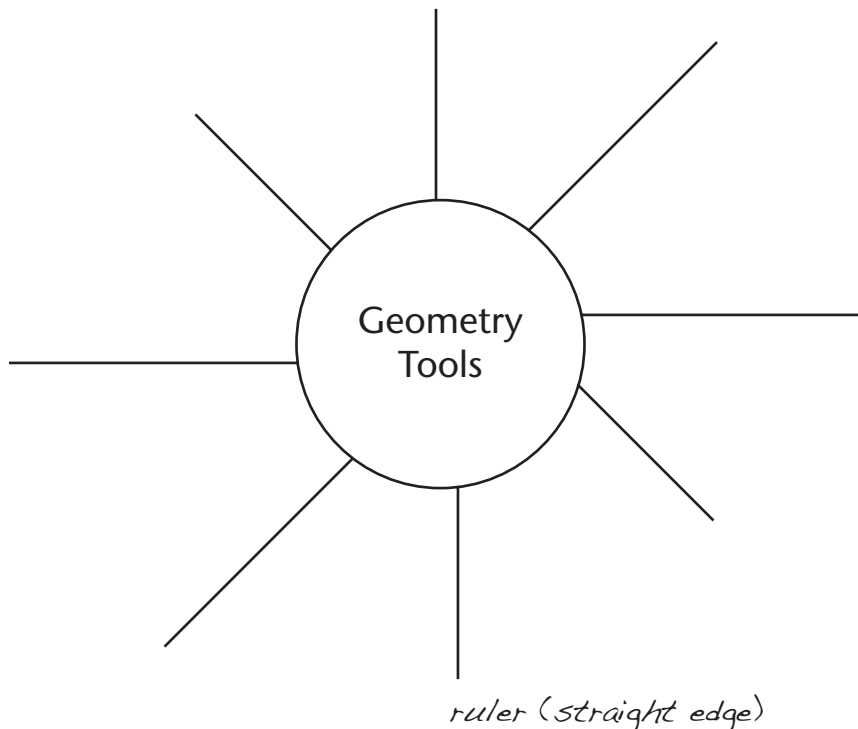





## Explore

The Ancient Egyptians were great builders—they constructed pyramids, sculptures, temples, and tombs. To build the pyramids they used a straight edge and a rope compass. Land surveyors, architects, engineers, and sculptors in Ancient Egypt all used the rules of geometry in their trade as people do today. Using a compass and straightedge is still the best way to do construction.

Think of what our houses would look like if carpenters didn't have tools to make straight edges, vertical walls, and square corners. The walls would not stand up straight, and the house might fall over, like a house built out of a deck of cards!

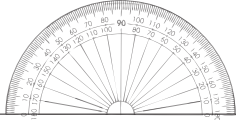
Here are some important geometry tools and terminology:

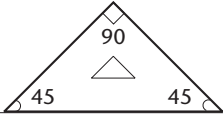
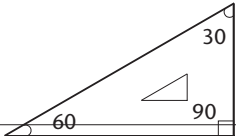
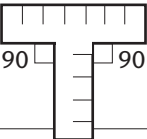
Protractor	You can use it to measure angles.	
Compass	You can use it to construct circles and arcs.	
Straight edge and/or ruler	You can use it to draw a straight line.	
45° right angle	You can use it to draw 45° angles and right angles (90°).	
30-60° right angle	You can use it to draw 30, 60, and 90° angles.	
Square or T-square	You can use it to draw right angles.	

## Thinking Space



Do you have any questions about the Ancient Egyptians or the techniques they used?

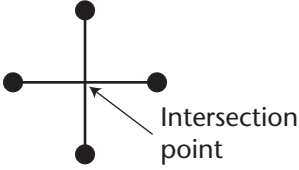
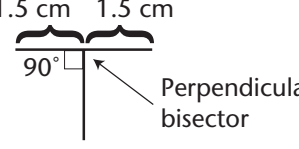
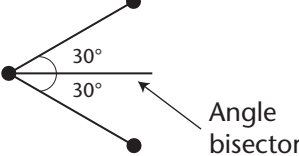

Intersection point	The point where two lines cross each other.	
Perpendicular bisector	A line that intersects a line segment at $90^\circ$ and divides it into two equal lengths.	
Angle bisector	A line that cuts an angle in half to form two equal angles.	

Can you think of any examples of these terms in your daily life?

Here are some examples:

- Framing Square and Level—Used to check that the wall is perpendicular to the floor.
- Intersection Point—Pedestrians must stop at the street intersection before crossing.
- Perpendicular Bisector—The letter T is a line segment with a perpendicular bisector.
- Angle Bisector—The fold line when you fold an equilateral triangle in half.





## Practice

Let's practise constructing shapes with your geometry tools.

1. Practise using the different geometry tools. Discover the many types of shapes you can make on your paper.

a. Can you draw a flower with petals using your compass?

b. Can you draw a  $30^\circ$ ,  $45^\circ$ ,  $60^\circ$  angle using only the triangles? Try measuring the angles with your protractor to see if you are correct.

c. Can you draw a star?

2. Ancient Egyptians built the pyramids using a rope compass and straightedge. Architects commonly use a square or triangle to draw a right angle. Can you think of some other situations where geometry tools would be useful? Try and write down at least three ways to use geometry tools.
  - 1.
  - 2.
  - 3.
  
3. Can you think of examples of perpendicular bisectors in everyday life (eg. A teeter-totter in the playground)? Can you describe examples of angle bisectors in the environment (eg. A pole holding up a triangular shaped tent)?

Let's review the new terminology that you have learned.

4. Fill in the blanks.

*Hint: if you're stuck, go back to the vocabulary table from earlier in the lesson.*

- a. You can use a \_\_\_\_\_ to construct circles and arcs.
  
- b. A \_\_\_\_\_ intersects a line segment at  $90^\circ$  and divides it into two equal lengths.



- c. One example of a perpendicular bisector is the letter \_\_\_\_\_.
- d. You can use a \_\_\_\_\_ to measure angles.
- e. You can use a \_\_\_\_\_ to measure  $30^\circ$ ,  $60^\circ$ , or  $90^\circ$  angles.
- f. You can use a \_\_\_\_\_ to draw a straight line.
- g. The \_\_\_\_\_ is where two lines cross each other.
- h. An \_\_\_\_\_ cuts an angle in half to form two equal angles.



Turn to the Answer Key at the end of the Module and mark your answers.



## Lesson 3.1C: Constructing Perpendicular Bisectors

### Student Inquiry



This activity will help you get ready for, learn, and review the information in the upcoming lesson.

When you turn this page over, you will find a chart containing the inquiry outcomes for this lesson. You may be able to answer some of these questions already! Start by writing down your thoughts before the lesson.

When you finish the lesson, answer each question and give an example.

	BEFORE THE LESSON	AFTER THE LESSON
<p>Student Inquiries</p> <p>How do I draw a line segment perpendicular to another line segment?</p> <p>How do I describe why they are perpendicular?</p> <p>How do I draw a perpendicular bisector of a line segment using different construction methods?</p>	<p>What I already know about this question:</p>	<p>What I thought at the end: My final answer, and examples:</p> <p>answer</p> <p>example</p> <p>answer</p> <p>example</p>
<p>How can I verify my results?</p>		<p>answer</p> <p>example</p>

## Lesson 3.1C: Constructing Perpendicular Bisectors

Thinking Space

### Introduction

Imagine that you and a friend are exploring in Egypt, searching for archeological treasure. You want to begin looking at the Great Pyramid and your friend wants to start searching at the Sphinx nearby. You want to find a meeting spot that is the same distance from the Pyramid and the Sphinx to meet for lunch. If you have a map and geometry tools, you can find the meeting spot on your map.

Let find's out how!



### Explore Online

Looking for more practice or just want to play some fun games?  
If you have internet access, go to the Math 7 website at:

<http://www.openschool.bc.ca/courses/math/math7/mod3.html>

Look for *Lesson 3.1C: Constructing Perpendicular Bisectors* and check out some of the links!



## Warm-up

In Lesson 3.1A, we talked about right angles and perpendicular lines. Look back to Lesson 3.1A, to review perpendicular lines. Perpendicular line segments are indicated by the symbol:  $\perp$

For example,  $AB \perp CD$ .

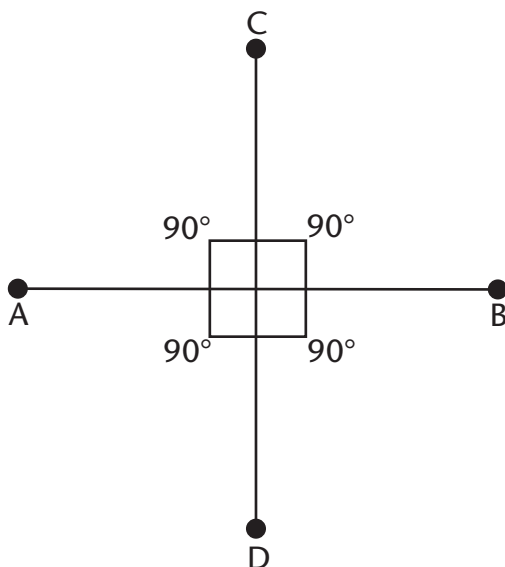

Recall that the symbol for a  $90^\circ$  angle or right angle is indicated by the symbol:  $\square$

In Lesson 3.1B, you learned that a perpendicular bisector is a line that intersects a line segment at  $90^\circ$  and divides it into two equal lengths. For example, the letter T is a line segment with a perpendicular bisector.

Thinking Space





## Explore

The Greek word **bisector** means “to cut into two equal parts” (*bi* = two and *sector* = cutting or dividing into parts).

There are many uses for perpendicular bisectors. You can draw a perpendicular bisector on a map to help you measure equal distances from two points. Perpendicular bisectors are very important to designers. For example, you can design a kitchen table or bridge and construct a perpendicular bisector that would act as the support post.

Can you think of any other examples?

Let’s find out how to construct perpendicular lines and bisectors using a variety of methods.

### Constructing Perpendicular Bisectors

#### Method 1: Folding Paper Construction

Step 1: Mark a point A on your page representing the pyramid.  
Mark a point B to represent the Sphinx.

Step 2: Draw a line segment between A and B with your ruler.

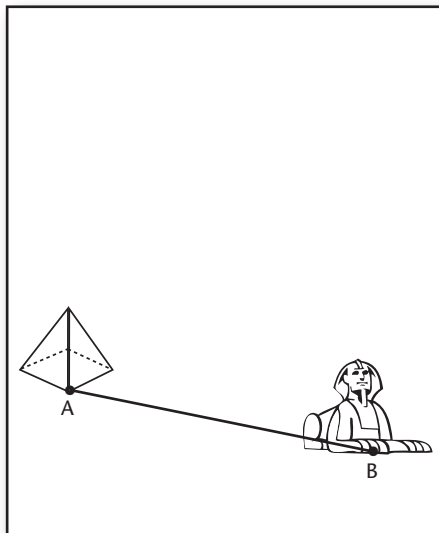

### Thinking Space



*Why does gravity make a perpendicular bisector important in building construction?  
How can we find the perpendicular bisector?*

Step 3: Fold the map so that A is directly on top of B.

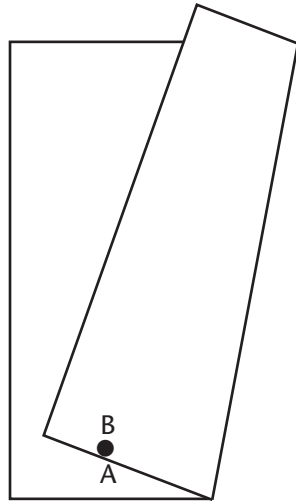

Step 4: Unfold the map and draw a line along the crease. This line is the perpendicular bisector. It forms a right angle with line segment AB.

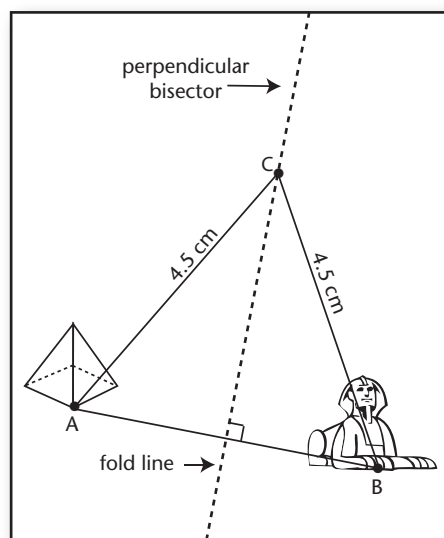

There are two ways to check your answer:

- Draw a point on the perpendicular bisector. This point should be the same distance from A and B.
- Measure the line segment with your ruler. The perpendicular bisector should divide the line in half. Use your protractor to measure the angle between the perpendicular bisector and line segment. It should equal  $90^\circ$ .

Thinking Space



## Method 2: Compass and Straight Edge Construction

Step 1: Mark a point A on your page representing the pyramid.  
Mark a point B to represent the Sphinx.

Step 2: With your ruler, draw a line segment from A to B.

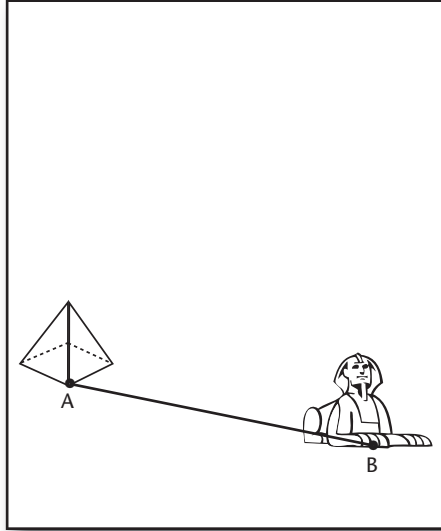

Step 3: Adjust your compass so that its radius is more than half of the distance between A and B. Tighten the screw so that the distance between the point and the pencil does not change.

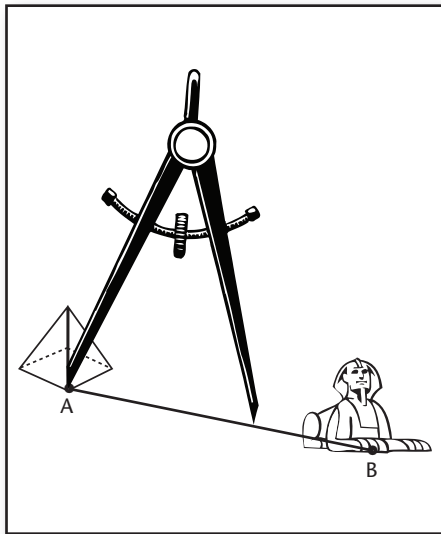

Step 4: With the compass point at A, draw an arc between A and B.

Step 5: Don't adjust your compass. With the compass point at B, draw another arc between A and B.

Thinking Space

- Step 6: The shape you have drawn is called a vesica. Label the top C and the bottom D. C and D are the two places where the arcs intersect.
- Step 7: Use a ruler to draw a line through C and D.

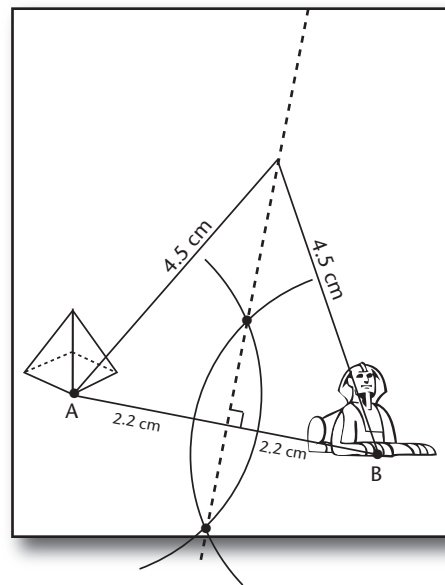
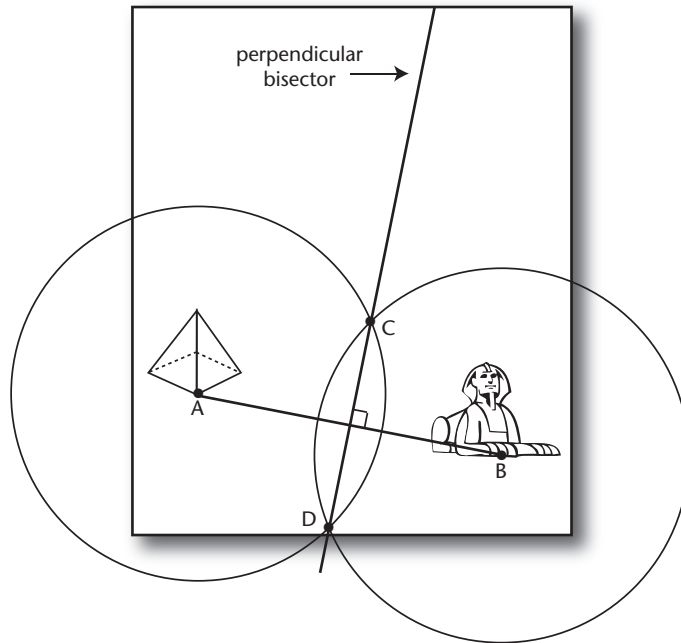

Line CD is perpendicular to line AB. How can you check this? Measure the angle with your protractor. It should be  $90^\circ$ .

Line CD bisects line AB. How can you check this? Measure the distance from A to the point of intersection. Measure the distance from B to the point of intersection. These measurements should be the same.

Line CD is the perpendicular bisector of CD.

### Method 3: Protractor and Ruler Construction

- Step 1: Mark a point A on your page representing the pyramid.  
Mark a point B to represent the Sphinx.
- Step 2: Draw a line segment between A and B with your ruler.

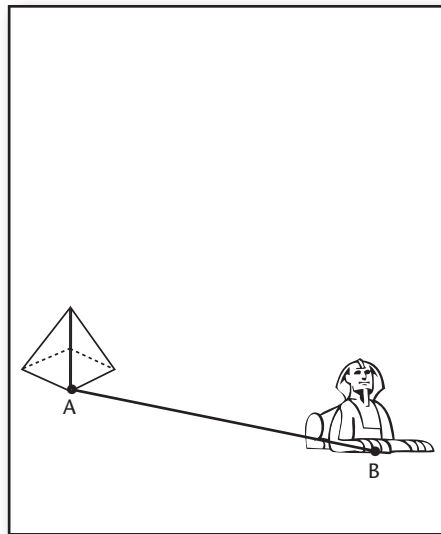

- Step 3: Measure the line segment with your ruler and mark the centre. Label the point C.
- Step 4: Place your protractor on the line segment AB, matching the vertex with point C.
- Step 5: Make a mark with your pencil at  $90^\circ$ .

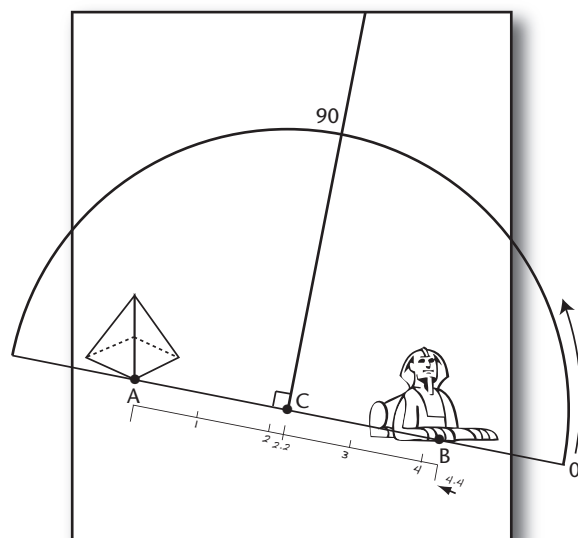

Thinking Space

Step 6: Draw a line from point C to the  $90^\circ$  mark. This is the perpendicular bisector.

Thinking Space

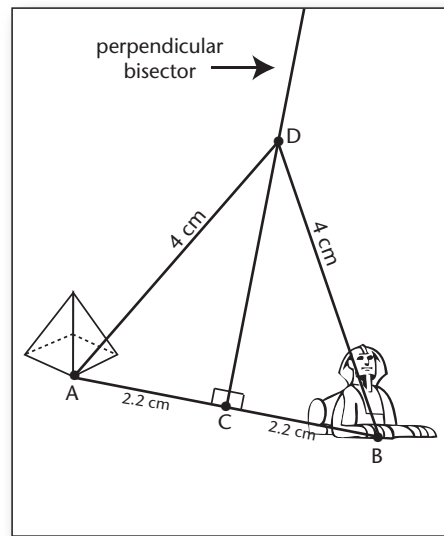

**Remember:** There are two ways to check your answer. Try them both!

#### Method 4: Right Triangle and Ruler

Step 1: Mark a point A on your page representing the pyramid. Mark a point B to represent the Sphinx.

Step 2: Draw a line segment between A and B with your ruler.

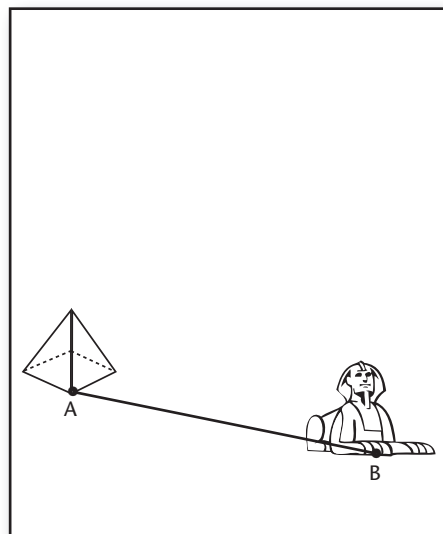

- Step 3: Measure the line segment AB with your ruler and mark the centre.
- Step 4: Label the centre Point C.
- Step 5: Place your right triangle on the line segment AB.
- Step 6: Draw a line along the edge of your triangle starting at Point C. This is the perpendicular bisector.

Thinking Space

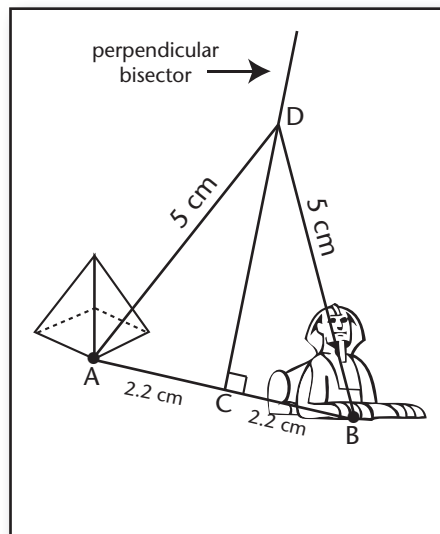
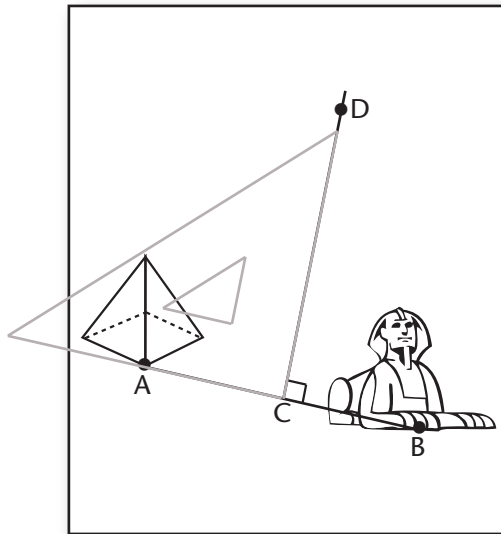

What is your favourite way to check your answer? Use it to make sure the line you drew really is a perpendicular bisector.





## Practice

1. Describe what perpendicular lines are.
2. What is the symbol for perpendicular lines?
3. Describe what the perpendicular bisector of a line segment is.
4. Draw a perpendicular bisector of a line segment using different construction methods. First, draw a line segment that is the indicated length. Then construct the perpendicular bisector using the given construction method.
  - a. 7 cm—compass and straight edge (ruler)

b. 10 cm—protractor and ruler

c. 17 cm—right angle and ruler

5. Can you make sure that the perpendicular bisector is correct?

6. This sign needs a post to support it. Draw where the perpendicular bisector support should be placed.





7. Dan and Megan decide to visit a zoo. They enter the zoo at different gates and want to meet up at a location that is close to the same distance from each gate. Which would be a better exhibit to meet at—the Zebras, the Monkeys or the Elephants?

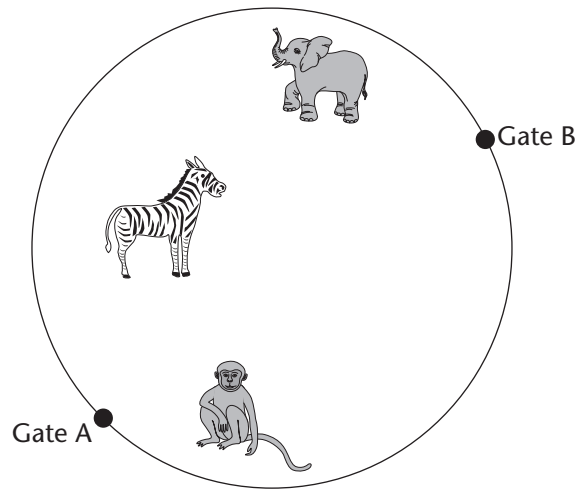

Turn to the Answer Key at the end of the Module and mark your answers.



## Lesson 3.1D: Constructing Angle Bisectors

### Student Inquiry

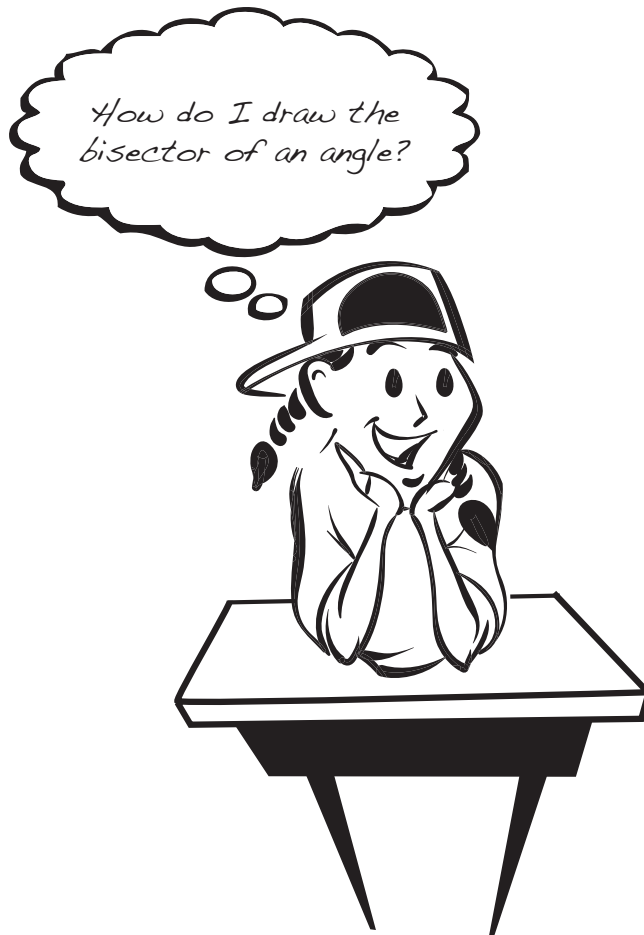

This activity will help you get ready for, learn, and review the information in the upcoming lesson.

When you turn this page over, you will find a chart containing the inquiry outcomes for this lesson. You may be able to answer some of these questions already! Start by writing down your thoughts before the lesson.

When you finish the lesson, answer each question and give an example.

	BEFORE THE LESSON	AFTER THE LESSON
<p>Student Inquiries</p>	<p>What I already know about this question:</p>	<p>What I thought at the end: My final answer, and examples:</p>
<p>How do I draw the bisector of a given angle? Is there more than one method that I could use?</p>		<p>answer</p> <p>example</p>
<p>How do I make sure that the angle bisector is correct?</p>		<p>answer</p> <p>example</p>

## Lesson 3.1D: Constructing Angle Bisectors

Thinking Space

### Introduction

You and your friend are planning a puppet show. You are in charge of building the puppet stage tent for the show. Your stage frame is finished, you've nailed the curtain material to cover the entrance. All is going well, but then you realize that there is no opening in the front of the tent to perform your show—and the tent is already finished! What are you going to do?

The entrance of the tent is in the shape of an equilateral triangle (all sides are equal). You will need to cut the material right down the middle of the triangle so that each flap is equal in size and can open to the side. In this lesson, you will learn how to cut angles in half, so that each side is equal.



### Explore Online

Looking for more practice or just want to play some fun games?

If you have internet access, go to the Math 7 website at:

<http://www.openschool.bc.ca/courses/math/math7/mod3.html>

Look for *Lesson 3.1D: Constructing Angle Bisectors* and check out some of the links!



## Warm-up

Before you begin this lesson, you may find it helpful to review Lesson 3.1A and how to use your protractor to measure angles. You may also find it helpful to review the terminology you learned in Lesson 3.1B.

Words such as angle bisector and perpendicular bisector seem a bit overwhelming at first. Don't worry, their meanings will make more sense as you work with them and learn how to construct these shapes.

## Thinking Space





## Explore

Remember from the last lesson that the Greek word **bisector** means to cut into two equal parts (bi = two and sector = cutting or dividing into parts). Angle bisector means to cut an angle into two equal angles.

Let's find out what an angle bisector looks like.

Step 1: Draw a right angle using your right triangle on paper.

Step 2: Label the points on the angle with W, X, Y, like the one shown below.

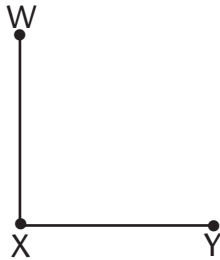

Step 3: Fold the piece of paper so that XY lies on top of WX.

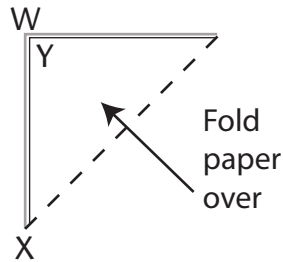

Step 4: Make a point on the fold crease and label it Z.

Step 5: Draw a line segment from X to Z on the fold crease. Line segment XZ is an angle bisector for  $\angle WXY$ .

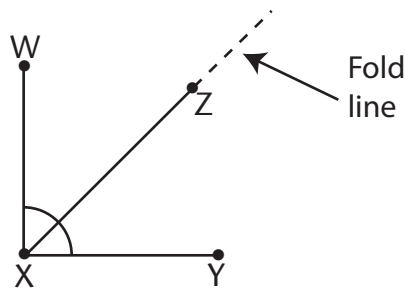

## Thinking Space



Use a protractor to measure the two angles: WXZ and ZXY.  
What do you notice about the two angles?

$$\angle WXZ = 45^\circ$$

$$\angle ZXY = 45^\circ$$

What can you conclude about an angle bisector?

### How To Draw an Angle Bisector:

You are colouring a chalk drawing in the park for a birthday party. You need to draw an arrow towards the picnic area in the park so that people know where to go. Using a right triangle, you can draw the arrowhead. How do you draw the angle bisector of the arrowhead to complete the arrow?



You can construct angle bisectors using a variety of tool combinations and methods.

Thinking Space





**Method 1: Draw an Angle Bisector with a Compass and Ruler**

- Step 1: Draw an angle and label it ABC.
- Step 2: Place your compass point on B and draw an arc that intersects AB and CB.
- Step 3: Label the intersection points D and E.

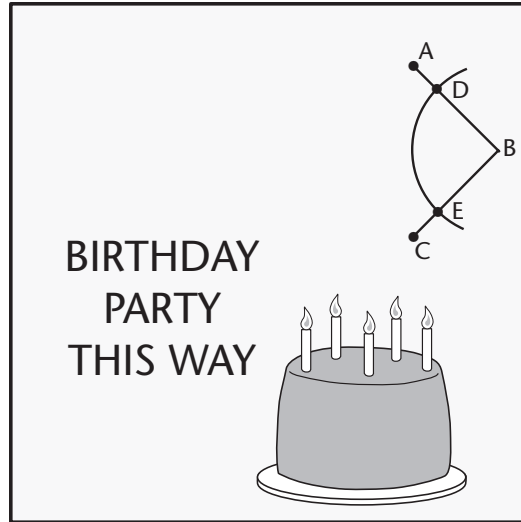

- Step 4: Place your compass on point D and draw an arc within the angle.
- Step 5: Without changing the radius of the compass, place your compass on point E and draw another arc within the angle.
- Step 6: Draw a line starting at B going through the intersection point of the two arcs. This is the angle bisector.

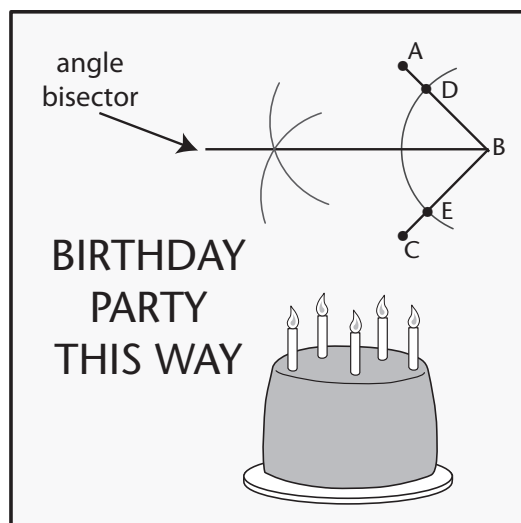

How to check: Use your protractor to measure the two angles. Are they the same?

Thinking Space

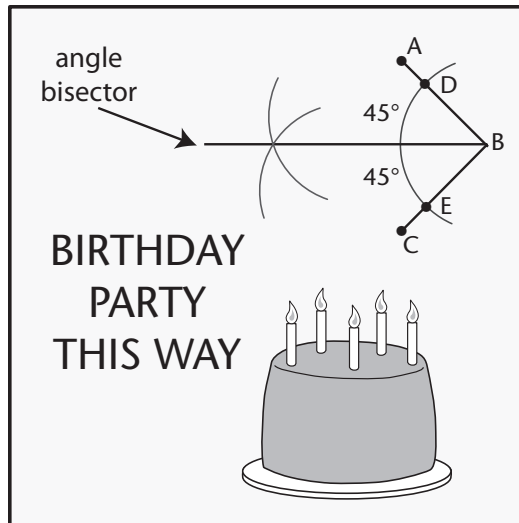

**Note:** If you placed a transparent mirror on the angle bisector line, Point D and line segment AB will be a reflection of Point E and line segment CB. These two points and angles are mirror images of each other.

### Method 2: Draw an Angle Bisector with a Protractor and Ruler

- Step 1: Draw an angle and label it ABC.
- Step 2: Measure angle ABC.
- Step 3: Write down the angle and divide it in half.

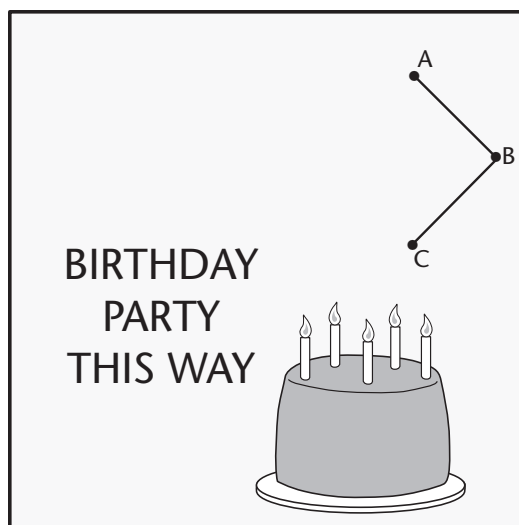

- Step 4: Place the base of your protractor on line segment CB.

Step 5: Centre the protractor on point B.

Step 6: Make a point D at the size of the angle you found in Step 3. (In this example, our angle is  $45^\circ$ ).

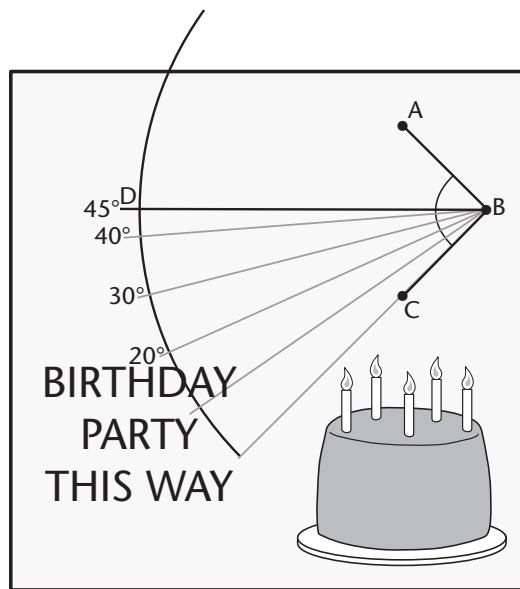

Step 7: Use a ruler to draw a line from B to D.

Step 8: Measure the two angles with your protractor to confirm they are equal.

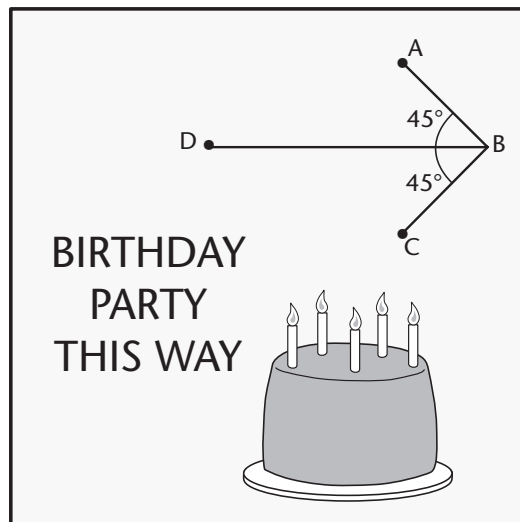

Step 9: Line segment DB is the angle bisector.

Which method do you prefer—the compass and ruler, or protractor and ruler? Why?





## Practice

1. Construct the angle bisector in the following angles.

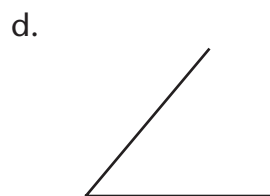
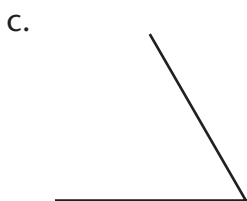

2. Draw a  $60^\circ$  angle with a square triangle. Construct the angle bisector using a compass and ruler.

3. Use a protractor to draw each angle. Then construct the angle bisector. Use a different method of construction for each angle.
  - a.  $130^\circ$  angle—compass and ruler

- b.  $70^\circ$  angle—protractor and ruler

4. Draw two triangles—one  $30 - 60^\circ$  triangle and one  $45^\circ$  triangle. Using the method that you prefer, draw angle bisectors for each angle in the two triangles. What do you notice about the bisectors?



Turn to the Answer Key at the end of the Module and mark your answers.

## Lesson 3.1E: Constructing Parallel Line Segments

### Student Inquiry



This activity will help you get ready for, learn, and review the information in the upcoming lesson.

When you turn this page over, you will find a chart containing the inquiry outcomes for this lesson. You may be able to answer some of these questions already! Start by writing down your thoughts before the lesson.

When you finish the lesson, answer each question and give an example.

	BEFORE THE LESSON	AFTER THE LESSON
<p>Student Inquiries</p> <p>How do I draw a line segment that is parallel to another line segment?</p>	<p>What I already know about this question:</p>	<p>What I thought at the end: My final answer, and examples:</p> <p>answer</p>
<p>Why are the two lines parallel?</p>		<p>example</p> <p>answer</p> <p>example</p>



## Lesson 3.1E: Constructing Parallel Line Segments

Thinking Space

### Introduction

Streets and avenues are a familiar way to remember the definition of parallel and perpendicular lines. Many cities are divided into East-West Avenues and North-South Streets (or vice versa). Looking at these cities from a birds' eye view, streets and avenues will form a grid of parallel lines and perpendicular lines. For example, Main Street and 1st Street will never intersect but run in the same direction. They are parallel to each other. Second Street and 1st Avenue will cross each other at a right angle ( $90^\circ$  angle) and create a traffic intersection.

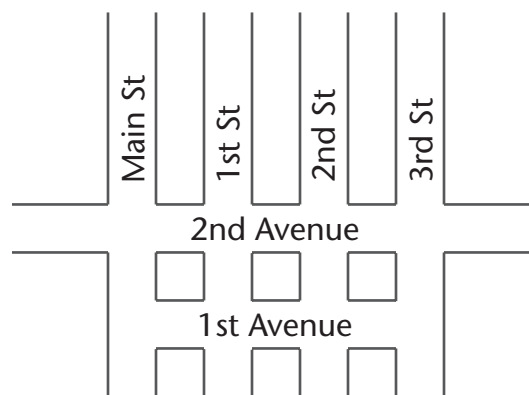

What shape is created at the intersection of two streets and an avenue?

If you said a square, you're correct!

A kitchen table top runs parallel to the floor. Think of what would happen if the table surface was not parallel with the floor. The food would probably fall off the table onto the floor!

The ability to draw parallel lines is a very important skill to have for engineers, carpenters, and architects.

Let's learn how to draw parallel lines!



### Explore Online

Looking for more practice or just want to play some fun games?

If you have internet access, go to the Math 7 website at:

<http://www.openschool.bc.ca/courses/math/math7/mod3.html>

Look for *Lesson 3.1E: Constructing Parallel Line Segments* and check out some of the links!





## Warm-up

You may find it helpful to review Lesson 3.1A and the definitions of parallel lines and line segments.

A line segment is a straight line between two points. It has two definite end points and a definite length.

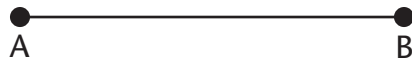

Parallel lines never meet. The two lines are always equally distant from each other.

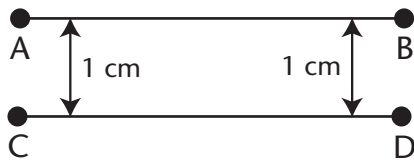

Parallel line segments are indicated by the symbol:  $\parallel$

For example, this means line segment AB is parallel to line segment CD.

$$\overline{AB} \parallel \overline{CD}$$

Thinking Space



## Explore

Which of the following line pairs are parallel? Even if two lines look parallel, they might not be—looks can be deceiving. How can you show that two lines are parallel?

a.

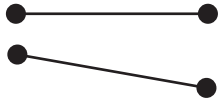

b.

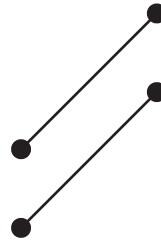

c.

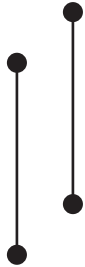

d.

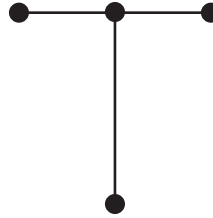

## Constructing Parallel Line Segments

### Method 1: Right Triangle and Ruler

- Step 1: Use a ruler to draw a line segment. Label the endpoints A and B.
- Step 2: Line up the longer edge of a 30°, 60° right triangle along the line segment AB.
- Step 3: Hold a ruler along the edge of the triangle.

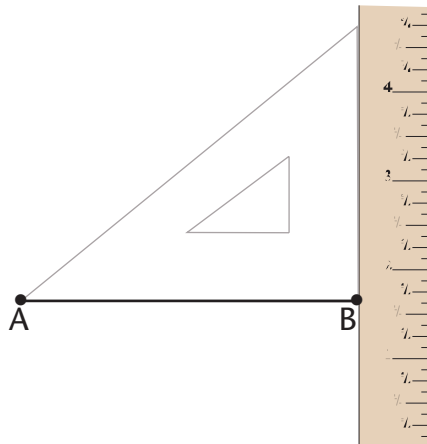

Thinking Space

Step 4: Slide the triangle downwards or upwards along the ruler.

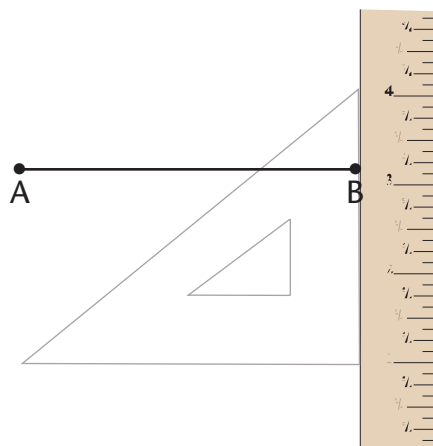

Thinking Space

Step 5: Draw a line segment parallel to  $\overline{AB}$ .

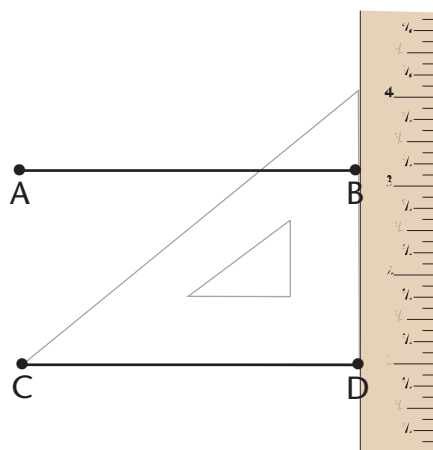

Step 6: Check your work. Measure the distance between the parallel line segments at two locations. If the two distances are equal in length, the line segments are parallel.

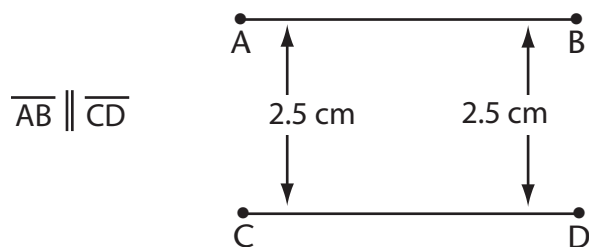

### Method 2: Compass and Ruler

Step 1: Use a ruler and draw a line segment (eg.  $\overline{AB}$  ).

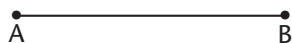

Step 2: Construct a perpendicular bisector on the line segment.

Step 3: Label two points (eg. C, D) on one arm of the perpendicular bisector.

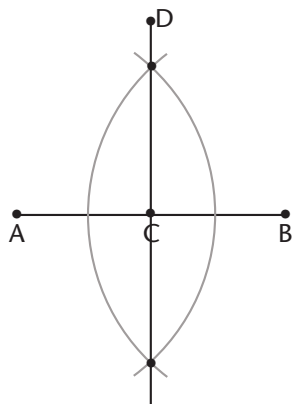

Step 4: Using these two points (C, D), construct the perpendicular bisector of this first perpendicular bisector. Label the second perpendicular bisector,  $\overline{EF}$ .

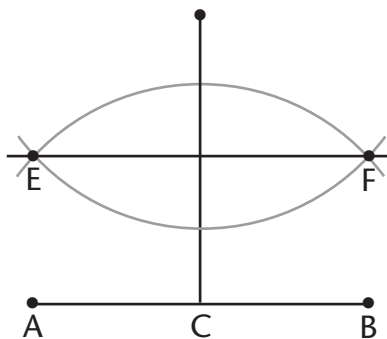

Line segment EF is parallel to line segment AB.

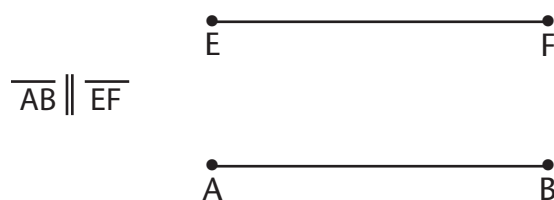

### Thinking Space



*We constructed perpendicular bisectors in Lesson 3.1C.*

### Method 3: Protractor and Ruler

Step 1: Draw a line segment with a ruler.

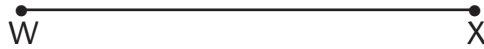

Step 2: Use your protractor to draw a  $90^\circ$  angle at both points W and X.

Step 3: Use your ruler to draw equal length perpendicular line segments from points W and X. Label the end points of each line segment (eg. Z, Y).



Step 4: Connect the perpendicular line segments with a line to create a rectangle.



The top and bottom line segments ( $\overline{WX}$  and  $\overline{ZY}$ ) are parallel. The two side line segments ( $\overline{ZW}$  and  $\overline{YX}$ ) are also parallel.

Thinking Space



## Practice

1. Which of the following line segments are parallel?  
Use your ruler to check your answer.

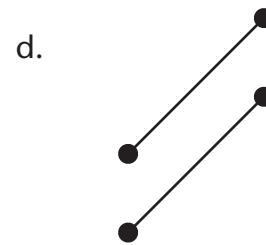
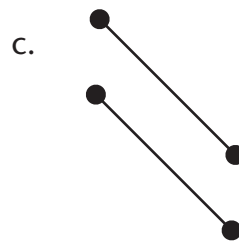
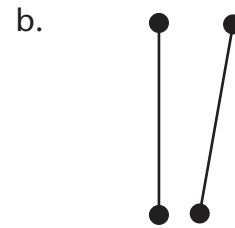
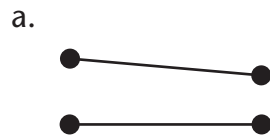

2. Draw two parallel line segments that are each 5 cm long using the compass and ruler method.

3. Draw a rectangle with length (6 cm) and width (3 cm) using the protractor and ruler method.

4. Draw two parallel line segments that are 4 cm apart using the Right Triangle and Ruler method.



Turn to the Answer Key at the end of the Module and mark your answers.



## Section Summary

### Line Segments

A line segment is a line between two given points. It has finite or defined length.

Examples:

This is a line segment:



This is a line (and not a line segment):



This is a ray:



A line and a ray have infinite or undefined length.

### Measure an Angle Using a Ruler and Protractor

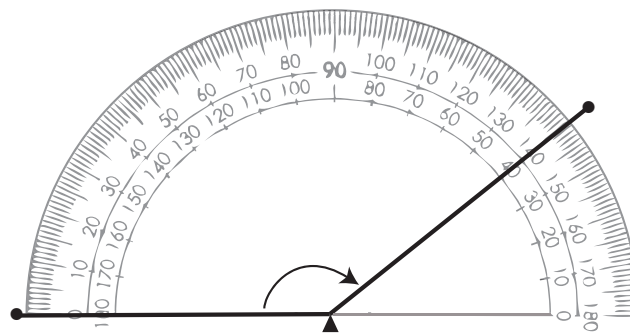

### Parallel Line Segments

These two line segments are parallel:



## Perpendicular Line Segments

These two line segments are perpendicular:

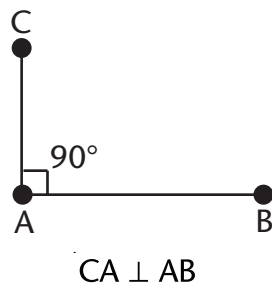

## How to Construct Perpendicular Bisectors

Method 1. Folding Paper

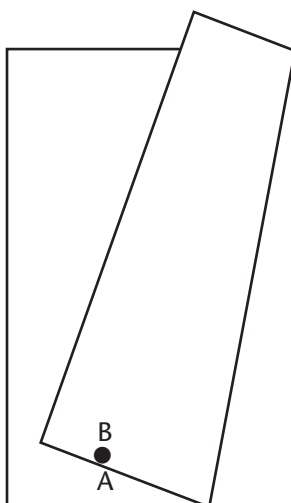

Method 2. Compass and Straight Edge

Use a compass to draw intersecting circles from two points on a line segment. Draw a line through the points of intersection. This line is the perpendicular bisector.

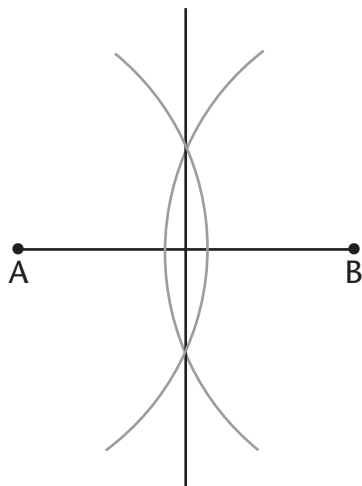

Method 3. Protractor and Ruler

Use a ruler to measure the midpoint on a line segment. Then use a protractor to draw a  $90^\circ$  angle at the midpoint.

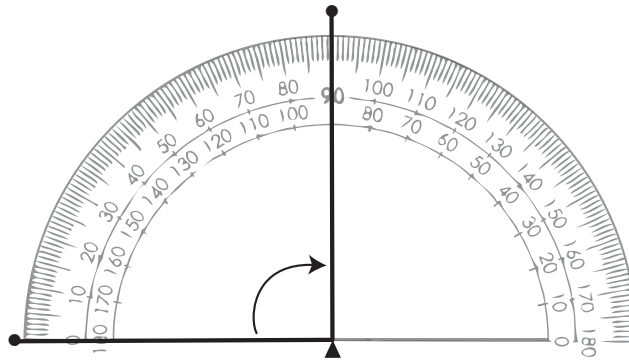

**How to Construct Angle Bisectors**

Method 1. Folding paper to Construct an Angle Bisector

Fold the line segments of an angle on top of each other. The fold-line is the angle bisector and it divides the angle in two.

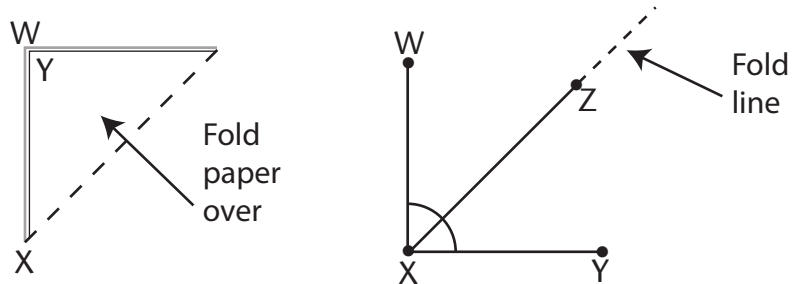

Method 2. Using a Compass and Ruler to Construct an Angle Bisector

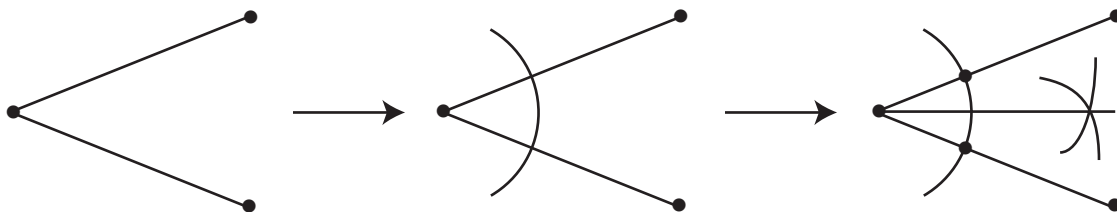

Method 3. Using a Protractor and Ruler to Construct an Angle Bisector

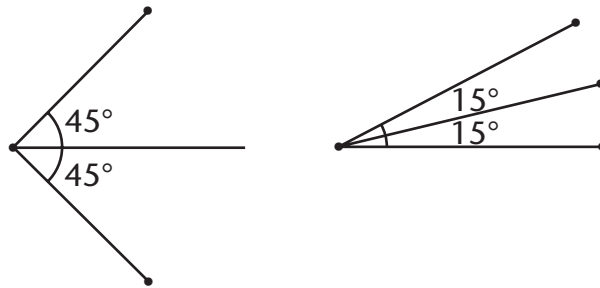

## How to Construct Parallel Line Segments

Method 1. Using a Right Triangle and Ruler to Construct Parallel Line Segments

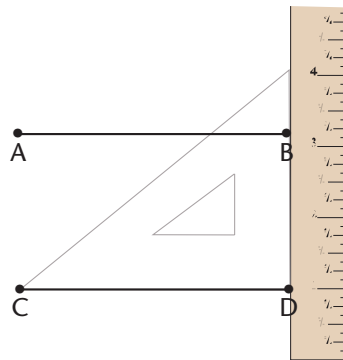

Method 2. Using a Compass and Ruler to Construct Parallel Line Segments

Construct the perpendicular bisector of a line segment. Then construct the perpendicular bisector of the first perpendicular bisector.

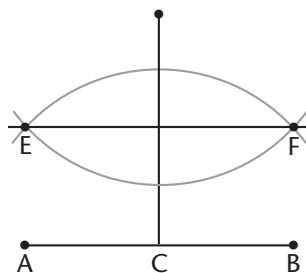

Method 3. Using a Protractor and Ruler to Construct Parallel Line Segments

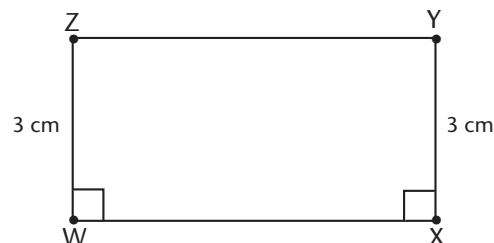

## Section Challenge

Sarah and Tom want you to design a tree house for their backyard. It sounds very exciting and you have lots of ideas. Quickly, you realize that there are many things that you will need to consider. To start, you'll have to choose a suitable tree. You'll also need to know how to draw parallel and perpendicular line segments. The floor of the tree house has to run parallel to the ground so that people can stand up straight. Also, the walls in the tree house have to run perpendicular to the floor, so that the walls won't fall over.

You'll need to design and build a ladder so that they can climb up to their tree house. Sarah and Tom's friends also want you to draw a map with an arrow pointing out the direction to the tree house, so they know how to find it.

Instructions are provided for you here, as well as space to complete your work. Feel free to use your own paper if you need more space. *Note: If you want, review the Section Challenge at the beginning of the section.*

1. On the site plan, draw line segments from the back door of Sarah and Tom's house to each of the trees in the yard.
2. Measure each line segment.
3. Choose the tree that is closest to the back door.

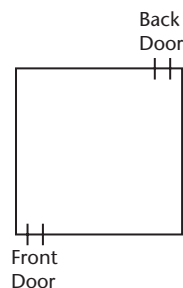

Now you need to design the tree house. Draw your design on the tree image on the next page.

4. Construct a parallel line segment between the ground and half way up the tree. This is the floor of the tree house, which needs to run parallel to the ground.
5. Construct perpendicular lines going upwards from both ends of the floor to make walls.

6. Design the tree house however you like. You should include a door, windows, and a  $30^\circ$  sloping roof.
7. Construct a perpendicular bisector from the bottom of the tree house to the ground, as a support post.
8. Construct a ladder going from the ground to the tree house. You need to construct parallel line segments to make the rungs of the ladder.
9. Add any other details you would like to complete the design of a tree house.
10. Sarah and Tom's friends will need a map with an arrow pointing out the direction to the tree house, so they know how to find it. On the top view map above, construct an arrow pointing out the direction to the tree house.

You need to draw an angle for the head of the arrow and an angle bisector as the tail of the arrow.

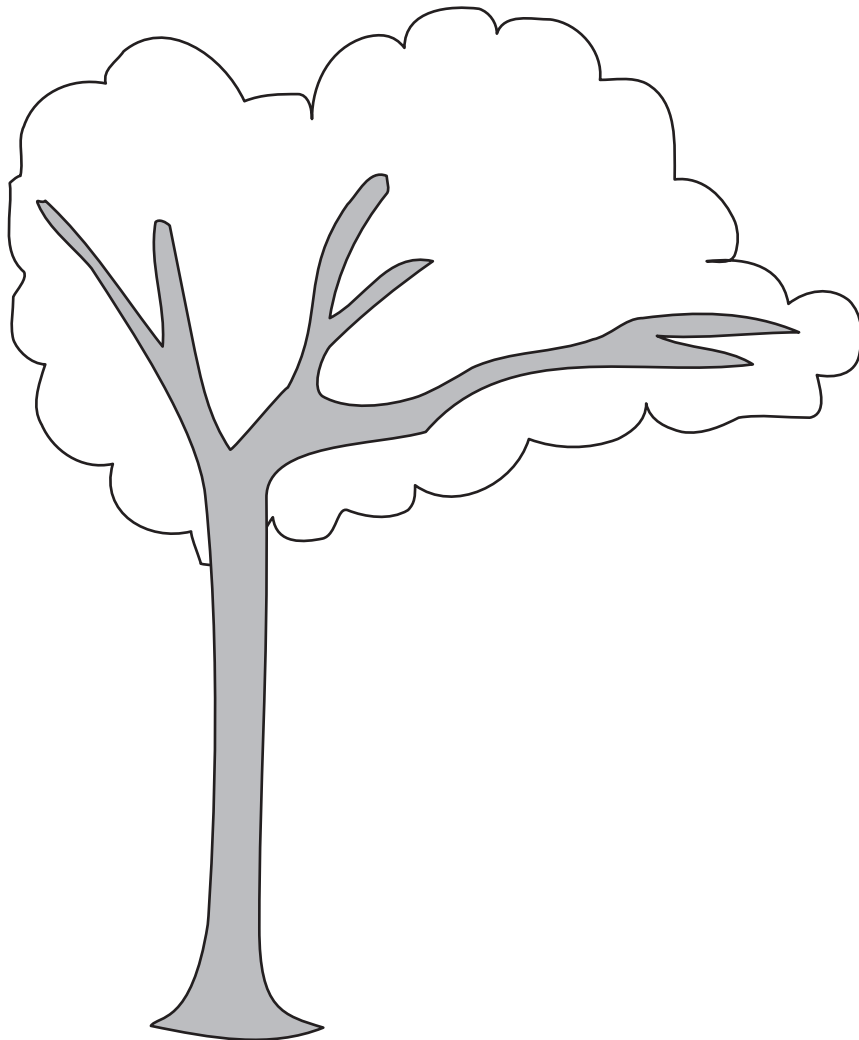

## Section 3.2: Areas of Polygons

# Section 2

### Contents at a Glance

Pretest	95
Section Challenge	98
Lesson A: How Do We Measure Things?	99
Lesson B: Finding the Area of Triangles	117
Lesson C: Finding the Area of Parallelograms	131
Lesson D: Problem Solving with Area	145
Section Summary	159

### Learning Outcomes

By the end of this section you will be better able to:

- describe the metric units of measurement.
- define the term polygon and identify examples of polygons.
- develop and use a formula to find the area of a triangle.
- develop and use a formula to find the area of a parallelogram.
- solve problems that involve finding the area of triangles and parallelograms.





## Pretest 3.2

Complete this pretest if you think that you already have a strong grasp of the topics and concepts covered in this section. Mark your answers using the key found at the end of the module.

If you get all the answers correct (100%), you may decide that you can omit the lesson activities.

1. Match the unit that you would use to measure the following items.

- |       |   |       |
|-------|---|-------|
| _____ | distance between Vancouver and Kamloops | a. mm |
| _____ | your own height                         | b. cm |
| _____ | length of a spider                      | c. m  |
| _____ | height of your closet                   | d. km |

2. Give the symbol for each of the following:

- a. three square metres \_\_\_\_\_
- b. five cubic metres \_\_\_\_\_
- c. one square centimetre \_\_\_\_\_
- d. two millimetres \_\_\_\_\_

3. Fill in the blanks.

a. 10 millimetres (mm) = \_\_\_\_\_ centimetre (cm)

b. 10 cm = \_\_\_\_\_ decimetre (dm)

c. \_\_\_\_\_ cm = 1 metre (m)

d. \_\_\_\_\_ m = 1 kilometre (km)

4. Find the volume of a box with a length of 4 cm, a width of 3 cm, and a height of 1.5 cm. Draw a diagram and label it.

5. A triangle has a base of 6 m. The height is 4 m. Find the area of the triangle.

6. Complete the following table. You are finding the base, height, or area for a parallelogram. Round your answer to two decimal places, if needed.

BASE	HEIGHT	AREA
125 m	25 m	
36 cm	18 cm	
10.2 m	8.4 m	
0.25 m	4.93 cm	
7 cm		49 cm <sup>2</sup>
	3.6 m	7.2 m <sup>2</sup>

7. Robyn has constructed a garden in the shape of a triangle. She wants to plant as many daffodils as she can. The base of the garden is 240 cm and the height is 3.5 m. She knows that she can plant 35 daffodils per square metre of garden. How many daffodils can she plant?



Turn to the Answer Key at the end of the Module and mark your answers.

## Section Challenge

The local recycling centre has asked you to design a poster for them. Part of the challenge is to use the least amount of paper. The recycling centre has a saying, “less is more!” They would like the poster to be in the shape of one of the triangles or parallelograms shown below. Can you choose the shape that would use the least amount of paper? In this section, you will learn how to find the area of triangles and parallelograms.

a.

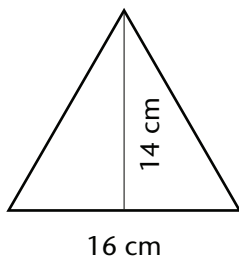

b.

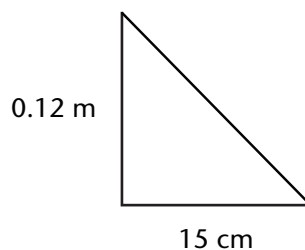

c.

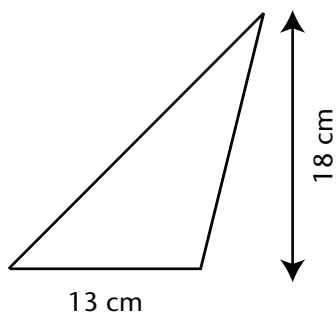

d.

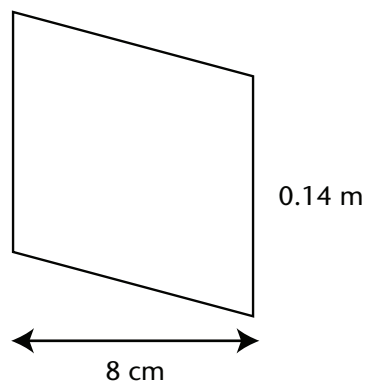

e.

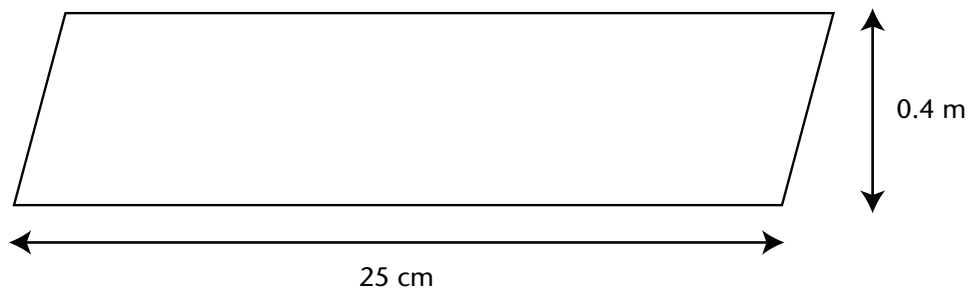

If you're not sure how to solve the problem now, don't worry. You'll learn all the skills you need to solve the problem in this section. Give it a try now, or wait until the end of the section—it's up to you!

## Lesson 3.2A: How Do We Measure Things?

### Student Inquiry



This activity will help you get ready for, learn, and review the information in the upcoming lesson.

When you turn this page over, you will find a chart containing the inquiry outcomes for this lesson. You may be able to answer some of these questions already! Start by writing down your thoughts before the lesson.

When you finish the lesson, answer each question and give an example.

	BEFORE THE LESSON	AFTER THE LESSON
<p>Student Inquiries</p> <p>What are the metric units of measurement?</p>	<p>What I already know about this question:</p>	<p>What I thought at the end: My final answer, and examples:</p> <p>answer</p> <p>example</p>
<p>What is a polygon?</p>		<p>answer</p> <p>example</p>
<p>What is perimeter and how do I measure it?</p>		<p>answer</p> <p>example</p>
<p>What is area and how do I measure it?</p>		<p>answer</p> <p>example</p>
<p>What is volume and how do I measure it?</p>		<p>answer</p> <p>example</p>

## Lesson 3.2A: How Do We Measure Things?

### Introduction

The word *geometry* comes from the Ancient Greek word *geometria* and means *to measure the Earth*.

Geometry was originally developed and used to measure common features of Earth, such as farmland. Every year in Ancient Egypt, the Nile River would overflow and wash away the markers that divided one farmer's field from another. Land surveyors used geometry to measure the fields so that farmers had equal sized farms. They marked off the land into shapes such as squares and triangles, and then calculated the area. By calculating the area, they could ensure that each farmer's field covered the same amount of land space.

In this lesson, you are going to review the different tools and units used to measure things. This is a quick lesson, but it's an important review. Soon, you too will be able to calculate the land area of a farmers' field, like the Ancient Egyptians. Good luck!



### Explore Online

Looking for more practice or just want to play some fun games?

If you have internet access, go to the Math 7 website at:

<http://www.openschool.bc.ca/courses/math/math7/mod3.html>

Look for *Lesson 3.2A: How Do We Measure Things?* and check out some of the links!

Thinking Space





## Warm-up

What tools and units would you use to measure the length of a stamp, width of a shoebox, or length of a soccer field?

Can you use the same measuring tool in each situation? You could use a ruler to measure the stamp and shoebox, but probably not to measure a soccer field.

Can you use the same unit of measurement? You could use centimetres to measure the stamp and shoebox, but probably not for the soccer field. You would probably use metres to measure the soccer field.

Let's review the metric units of measurement.

### Length/Width

10 millimetre (mm) = 1 centimetre (cm)

10 cm = 1 decimetre (dm)

100 cm = 1 metre (m)

1000 m = 1 kilometre (km)

### Unit Conversions

Can you convert one metric unit of measurement into another metric unit of measurement?

Here are some examples for you to review.

How many metres are equal to 125 cm?

100 cm = 1 m

You divide 125 cm by 100 = 1.25 m

How many centimetres are equal to 0.34 metres?

1 m = 100 cm

You multiply 0.34 m by 100 cm = 34 cm

Thinking Space





Here's a method you can use to visualize conversions:

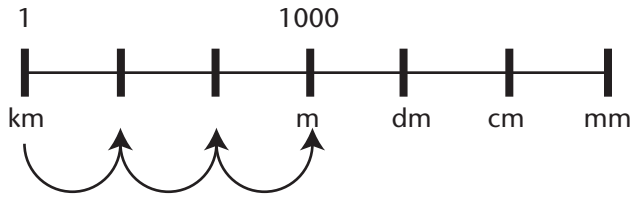

km to m  
Add 3 zeros  
 $1 \text{ km} = 1000 \text{ m}$

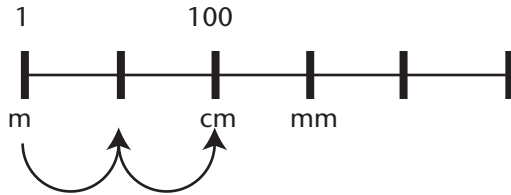



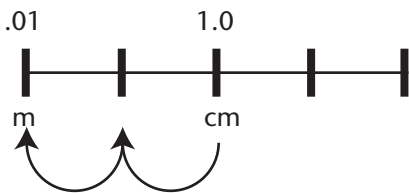



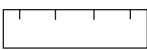
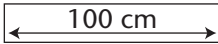
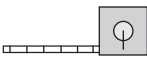

m to cm  
Add 2 zeros  
 $1 \text{ m} = 100 \text{ cm}$



cm to m  
Move the decimal point 2 spaces  
 $1.0 \text{ cm} = 0.01 \text{ m}$

## Tools of Measurement

Ruler		Most are 30 cm in length or 300 mm.
Metre stick		1 m in length (or 100 cm).
Tape measure		Most are marked in centimetres and inches. Used to measure distances in and around the house (eg. walls and floors).
Rope or chain		Knots in the rope or links in the chain are a given distance from one another. (eg. length between knots = 1 m. 5 knots in length is = 5 m)

Trundle wheel		<p>Used to measure long distances. It is made up of a wheel, a handle, and a clicking device that clicks after one revolution of the wheel. The circumference of the wheel (distance around) is exactly 1 metre. One revolution of the wheel equals 1 metre distance traveled on the ground. Every time the wheel makes a rotation, a click is heard and counted. The total number of clicks counted equals the number of metres traveled.</p>
Protractor		<p>Used to measure angles (0 to 180°).</p>
Compass		<p>Can be used to measure distances of line segments.</p>
Pencil		<p>Used to mark points or line segments.</p>
Straight edge		<p>Used to draw a line between points which is then measured.</p>
Chalk line		<p>The chalk string is stretched between two points. The string is snapped in the middle, leaving a chalk line that is then measured.</p>



## Explore

In this section, you will be learning how to measure shapes known as polygons. The Greek word *polygon* means *many angles*. A polygon is a shape with straight sides. Polygons are named according to the number of sides and angles they have. For example, a triangle has three sides and three angles. Two other familiar polygons are the square and rectangle.

Here are some examples of polygons:

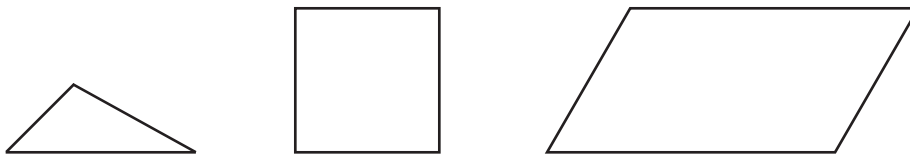

These are not polygons.



Why do you think they are not polygons?

Unlike polygons, these shapes are made up of curves, not just straight line segments.

## Measuring Line Segments, Polygons, and Solid Objects

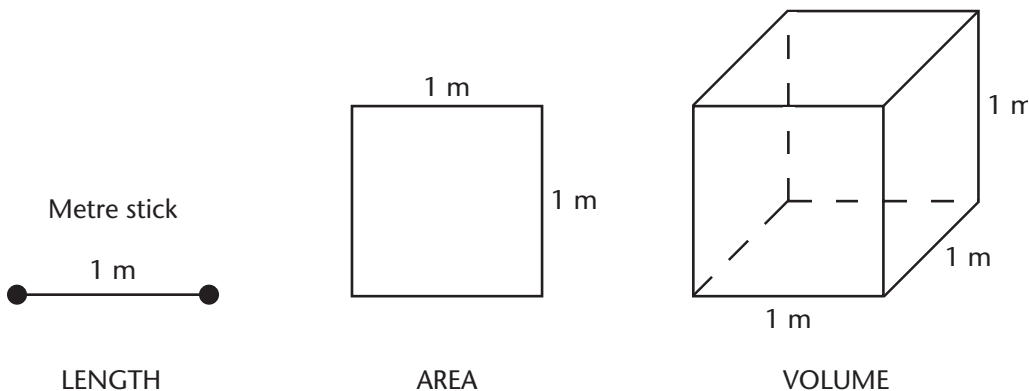

Thinking Space



Line segments are one-dimensional, which means you can measure the length of a line segment with a ruler.

Plane figure polygons are two-dimensional and you can measure the perimeter (using length of sides), but must calculate the area (using length and width).

Solid objects are three-dimensional and you can measure their perimeter, and calculate their surface area and their volume (using length, width, and height).

## Perimeter of Common Polygons—Triangles and Rectangles

The perimeter is the distance around the polygon or sum of the lengths of the sides. We measure perimeter in the same units as specified on the figure. For example, if the length of the side is measured in cm, the perimeter will be in centimetres. Let's look at two examples:

### Triangles

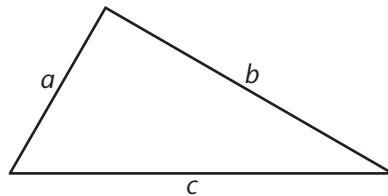

$$\text{Perimeter of a triangle} = a + b + c$$

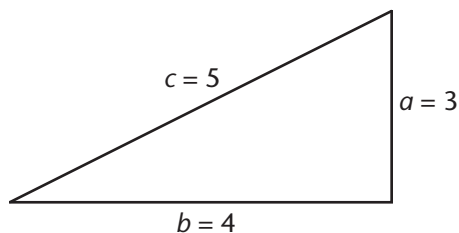

$$P = a + b + c$$

$$P = 3 + 4 + 5$$

$$P = 12$$

The perimeter of  $\triangle ABC$  is 12 cm.

## Rectangles

$l$  stands for the length of the rectangle and  $w$  stands for the width.

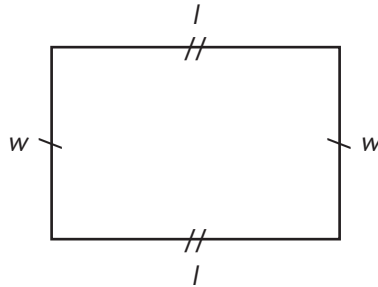

Perimeter of a rectangle =  $l + w + l + w$  (You have 2  $l$ s and 2  $w$ s)

$$P = 2l + 2w$$

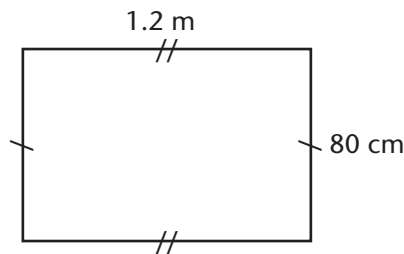

What do you notice about the metric units of the length and width in this figure? Before the perimeter can be calculated, the length of each side must be in the same metric unit. Here, we must change both length and width to metres, or both to centimetres.



In centimetres:	In metres:
$l = 1.2 \text{ m}$ $1.2 \times 100 = 120 \text{ cm}$ $w = 80 \text{ cm}$	$l = 1.2 \text{ m}$ $w = 80 \text{ cm}$ $80 \text{ cm} \div 100 = 0.8 \text{ m}$
$P = 2l + 2w$ $P = (2 \times 120) + (2 \times 80)$ $P = 240 + 160$ $P = 400 \text{ cm}$	$P = 2l + 2w$ $P = (2 \times 1.2) + (2 \times 0.8)$ $P = 2.4 + 1.6$ $P = 4 \text{ m}$
The perimeter is 400 cm OR 4 m.	

## Metric Units of Area

Area is the amount of surface within a shape. Do you remember how to measure the area within the rectangle?

You'll now have to consider two dimensions of the figure to find area: length and width. Perimeter is measured in linear units such as centimetres or metres. Do you think the metric unit used to measure area will be different from the linear units used to measure perimeter?

We measure area in square units such as "square metres ( $m^2$ )" and "square centimetres" ( $cm^2$ ).

You can think of **area** as the number of square units that covers a closed figure.

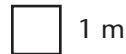
 1 m

The standard metric unit of area is the square metre. This is the area contained in a square that is 1 metre by 1 metre (or  $m \times m$ ). Using what we know about exponents,  $m \times m$  can also be written as  $m^2$ . We say "1 square metre" when we see the unit  $1 m^2$ .

What unit would you use to measure large distances, like the distance between Vancouver and Calgary? What unit would you use to measure small distances, like the distance between the wings of a butterfly?

To measure large areas of land, the square kilometre is used. To measure small areas, you might use the square millimetre.

**Remember:** Measurements of area must always include a unit of measurement. Your answer will not be complete if you do not include the unit of measurement. For example, "5" does not mean the same as "5 m" or "5  $m^2$ ." Always be sure to include a unit of measurement whenever you are recording linear, area, or volume measurements.

1 $mm^2$	1 square millimetre
1 $cm^2$	1 square centimetre
1 $dm^2$	1 square decimetre
1 $m^2$	1 square metre
1 $km^2$	1 square kilometre

### Thinking Space



*You can also say "one metre squared".*

## Area of Rectangles

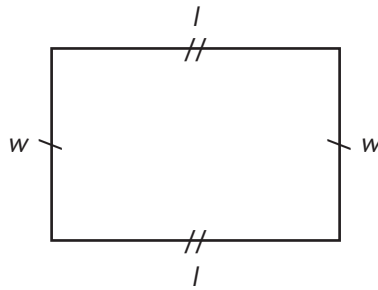

Area of a rectangle =  $l \times w$

$$A = lw$$

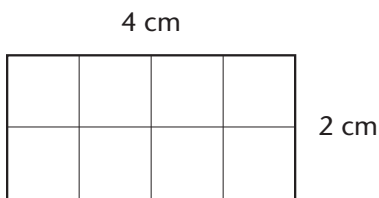

$$A = lw$$

$$A = 4 \times 2$$

$$A = 8 \text{ square centimetres or } 8 \text{ cm}^2$$

The area is  $8 \text{ cm}^2$ .

One centimetre is equal to one hundredth of a metre. It is important that you do not treat  $1 \text{ cm}^2$  as being equal to one hundredth of a square metre. Let us see why this is so.

Suppose you want to calculate the area of a piece of carpeting that is 1 metre by 1 metre.

Area = length  $\times$  width

$$A = 1 \text{ m} \times 1 \text{ m}$$

$$A = 1 \text{ m}^2$$

The area of the carpet is  $1 \text{ m}^2$ .

Since 1 metre = 100 centimetres, you can also calculate the area of the piece of carpet in square centimetres.

$$A = l \times w$$

$$A = 100 \times 100$$

$$A = 10\,000 \text{ cm}^2$$

The area of the carpet is  $10\,000 \text{ cm}^2$ .

Therefore, 1 square metre is made up of 10 000 square centimetres.

Thinking Space



## Metric Units of Volume

Volume is the amount of space occupied by a 3-dimensional (solid) object. Volume is measured in cubic units.

The standard metric unit of volume is the cubic metre. This is the space contained in a cube that is 1 metre long, 1 metre wide, and 1 metre high.

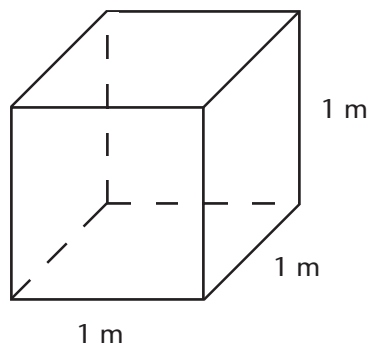

The symbol for cubic metre is  $1 \text{ m}^3$ .

If length, width, and height are measured in centimetres, the volume is measured in cubic centimetres.

The symbol for cubic centimetres is  $1 \text{ cm}^3$ .

One cubic centimetre =  $1 \text{ cm} \times 1 \text{ cm} \times 1 \text{ cm} = 1 \text{ cm}^3$

One cubic millimetre =  $1 \text{ mm} \times 1 \text{ mm} \times 1 \text{ mm} = 1 \text{ mm}^3$

Volume of a box = length  $\times$  width  $\times$  height

How many cubes measuring 1 cm by 1 cm by 1 cm ( $1 \text{ cm}^3$ ) do you think will fit in this box?

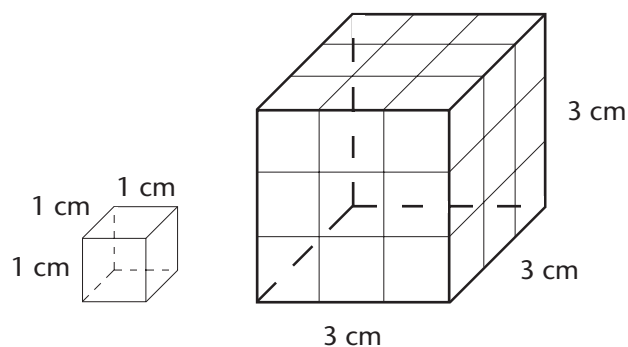



Volume = 3 cm × 3 cm × 3 cm

$V = 27 \text{ cm}^3$

You can fit 27 cubes measuring 1 cm by 1 cm by 1 cm ( $1 \text{ cm}^3$ ) into the box.

Here's a quick reference for measuring length, area, and volume:

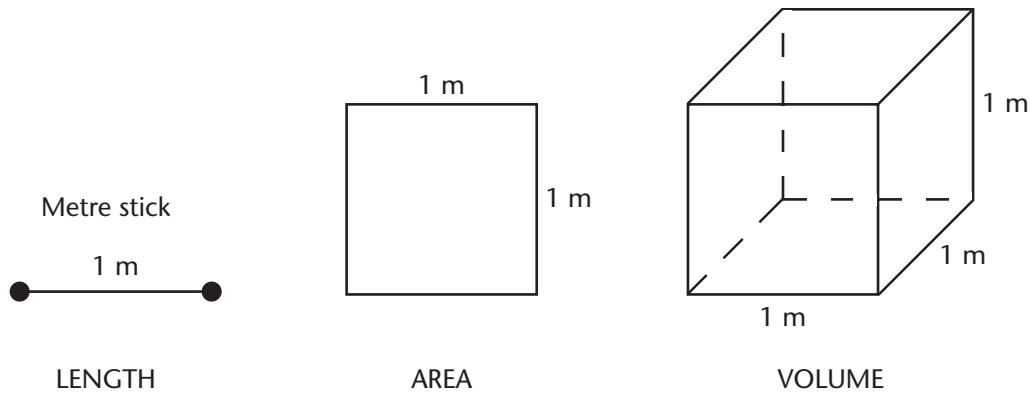

The metre stick is **1 metre in length.**

One dimension:  
**length**

The square is 1 metre by 1 metre, or **1 square metre in area.**

Two dimensions:  
**length and width**

The cube is 1 metre by 1 metre by 1 metre, or **1 cubic metre in volume.**

Three dimensions:  
**length and width and height**

Thinking Space



## Practice

1. Match each tool to the situation where you would use the tool.

- |       |  |                  |
|-------|--|------------------|
| _____ | used to measure the length of your living room                               | a. Ruler         |
| _____ | used to measure the length around a garbage can                              | b. Metre stick   |
| _____ | used to measure the length around a park                                     | c. Tape measure  |
| _____ | used to measure the angle between the hands of a clock pointing at 3 o'clock | d. Rope or chain |
| _____ | used to measure the height of your Science Fair backboard                    | e. Trundle wheel |
| _____ | used to measure the length of a line segment                                 | f. Protractor    |

2. Match the unit that you would use to measure the following items:

- |       |  |       |
|-------|--|-------|
| _____ | distance between Vancouver and Calgary | a. mm |
| _____ | your own height                        | b. cm |
| _____ | length of a ladybug                    | c. m  |
| _____ | height of your closet                  | d. km |

3. Give the symbol for each of the following:

a. two square metres \_\_\_\_\_

b. five cubic metres \_\_\_\_\_

c. one square centimetre \_\_\_\_\_

d. four millimetres \_\_\_\_\_

e. one cubic millimetre \_\_\_\_\_

f. three square kilometres \_\_\_\_\_

g. one kilometre \_\_\_\_\_

h. three cubic centimetres \_\_\_\_\_

i. five square millimetres \_\_\_\_\_

j. two centimetres \_\_\_\_\_

4. Find the perimeters of these polygons and include units:

a.

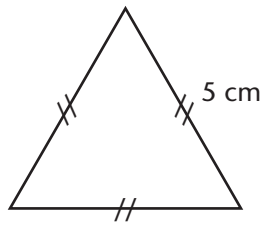

P = \_\_\_\_\_

b.

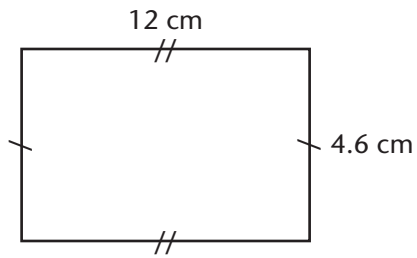

P = \_\_\_\_\_

c.

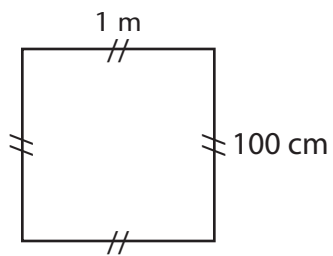

P = \_\_\_\_\_

5. Rectangles can have the same perimeter yet be different in area.  
Complete the table by finding the area of these rectangles.  
*Note: Areas are in square metres or  $m^2$ .*

a.

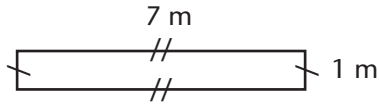

b.

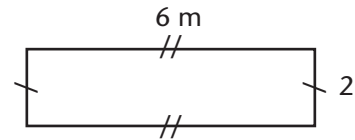

c.

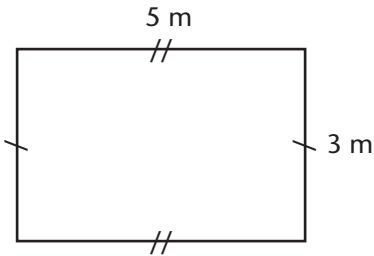

d.

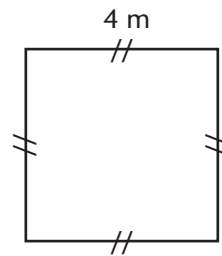

	<b>l</b>	<b>w</b>	<b>P</b>	<b>A</b>
a.	7 m	1 m	16 m	
b.	6 m	2 m	16 m	
c.	5 m	3 m	16 m	
d.	4 m	4 m	16 m	

6. Find the volume of this box and include units.

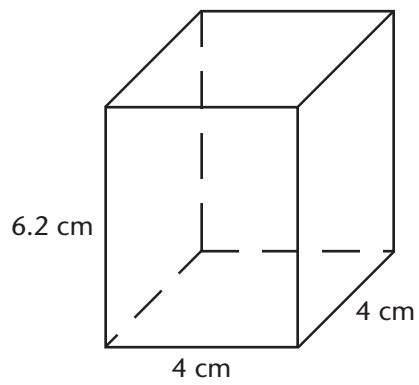

$V =$  \_\_\_\_\_



Turn to the Answer Key at the end of the Module and mark your answers.

## Lesson 3.2B: Finding the Area of Triangles

### Student Inquiry

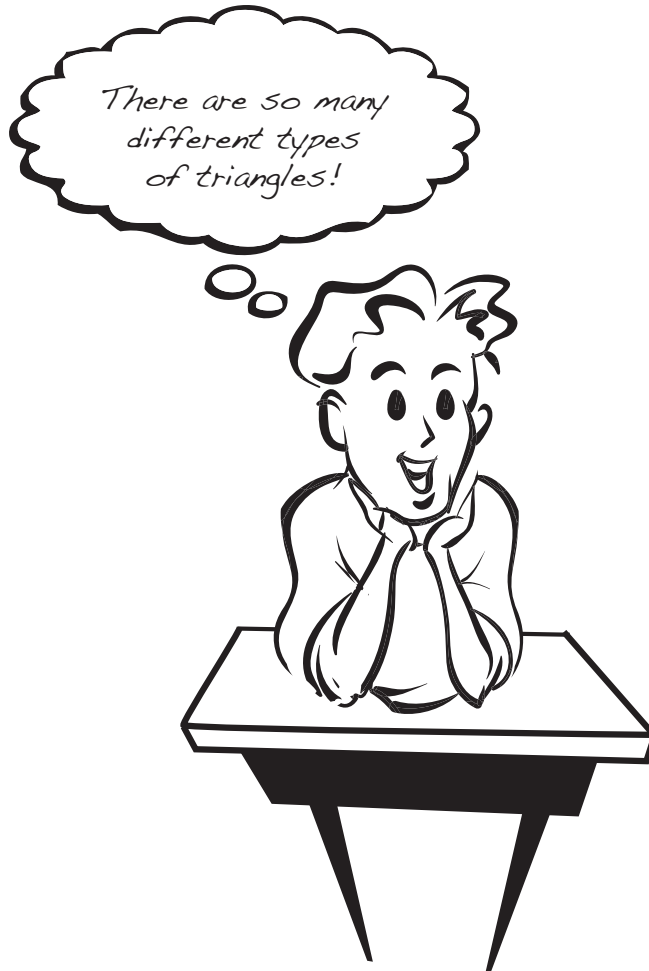

This activity will help you get ready for, learn, and review the information in the upcoming lesson.

When you turn this page over, you will find a chart containing the inquiry outcomes for this lesson. You may be able to answer some of these questions already! Start by writing down your thoughts before the lesson.

When you finish the lesson, answer each question and give an example.

	BEFORE THE LESSON	AFTER THE LESSON
Student Inquiries	What I already know about this question:	What I thought at the end: My final answer, and examples:
How can I use the area of a rectangle to find the area of a triangle?		answer
Can I create a formula to determine the area of triangles?		example
		answer
		example



## Lesson 3.2B: Finding the Area of Triangles

Thinking Space

### Introduction

Triangles are one of the most common polygons. Architects and engineers use the triangle in many of their designs because of the strong qualities of a triangle. Triangle shapes are much more difficult to distort than squares, rectangles, or circular shapes. You can easily distort a square box or a rubber ball with your hands. Just push the two corners together of a cardboard box and it flattens. Not so with a triangle. Try making a triangle with toothpicks and frozen peas. Gently press on the top of the triangle. Your triangle will hold its shape!

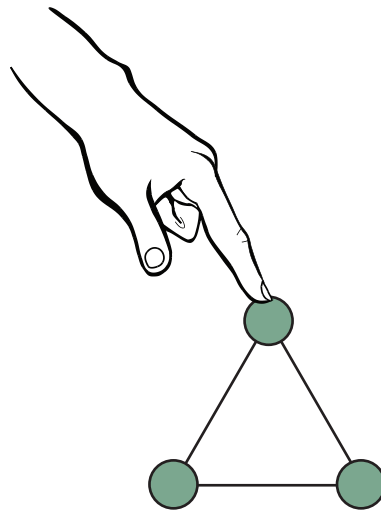

Just look around at things in your daily life and see if you can spot some triangles. Can you see a triangle at the top of a kite? In the sails of a sailboat? In the truss holding up a bridge or railroad over a river? Most houses have triangular rooftops so that rain and snow can easily slide off the top of the house onto the ground. Triangles are included in many familiar building designs such as the Eiffel Tower or Sydney Opera House, or in quilt designs such as the Pinwheel.

In this lesson, you will learn how to create a formula for determining the area of triangles by folding a piece of paper in half.

You'll need graph paper to complete the activities in this lesson.





## Warm-up

A triangle is a shape with three sides and three angles. *Tri* means *three* in Greek, so triangle simply means three angles. Connect any three points with line segments and you have a triangle. Just make sure that all three points aren't on the same line.

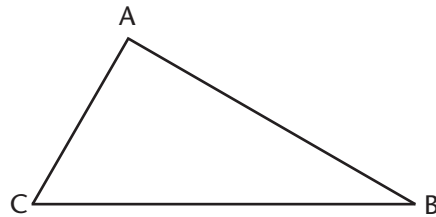

Line segments AB, BC, and CA are the sides of the triangle.

Points A, B, and C are each called a vertex of the triangle.

Points A, B, and C are the vertices of the triangle. (*Vertices* is the plural of *vertex*.)

We name a triangle by naming its vertices. We say "triangle ABC," and we write  $\triangle ABC$ . ALWAYS label vertices with capital letters.

### Try This!

- Step 1: On a piece of paper, draw three different shaped triangles. (They can be any size.)
- Step 2: Cut out the three triangles.
- Step 3: Tear off the three corners of one of the triangles.
- Step 4: Place the corners on a protractor to measure the total angle of all three corners.
- Step 5: Repeat Steps 3 – 4 for the two other triangles.

What did you notice about the three corners of each triangle?

### Thinking Space



## Types of Triangles

Is it possible to have a triangle with three  $90^\circ$  angles? The mathematician Roger Penrose was the first person to draw a particularly tricky triangle on paper. It's called the Penrose Triangle. Each angle in the Penrose Triangle looks like it is a right angle. Why is it impossible to make a real 3-Dimensional triangle like this?

Try making your own Penrose triangle with three pencils. You'll quickly see it's impossible! All angles in a triangle *must* add up to  $180^\circ$ . The angles in a Penrose Triangle add up to  $270^\circ$ , so it is not a real triangle, and only an illusion drawn on paper.

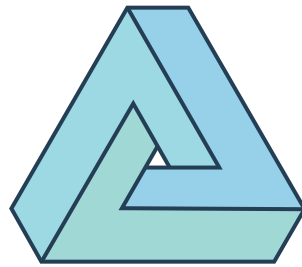

There are many different types of triangles, as you will see below. However, all triangles have one thing in common: the angles of a triangle always add up to  $180^\circ$ .

Triangles can have names related to their sides:

NAME	EXAMPLE	DEFINITION
Equilateral Triangle		Three equal sides Three equal angles Each angle is $60^\circ$
Isosceles Triangle		Two equal sides Two equal angles
Scalene Triangle		No equal sides No equal angles

Thinking Space

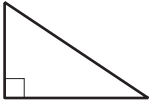
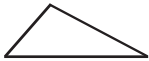

Triangles can also have names that are related to the angles inside:

NAME	EXAMPLE	DEFINITION
Acute Triangle		All angles are less than $90^\circ$
Right Triangle		Has a right angle ( $90^\circ$ )
Obtuse Triangle		Has an angle more than $90^\circ$

Thinking Space





## Explore

It's important that you start using the word *base* for length and *height* for width when you're working with triangles.

When you're measuring the length and width of a triangle, the length is called base and the width is called height.

<p>length = base width = height</p>
---

### Use the Area of a Rectangle to Find the Area of a Triangle

You can use the area of a rectangle to find the area of a triangle. Let's find out how by following the steps:

- Step 1: On graph paper, draw two different sized rectangles with your pencil and ruler.
- Step 2: Use your scissors to cut out the two rectangles.
- Step 3: Figure out the length of the base and height for each rectangle. You can do this by counting how many squares are along the base and height.

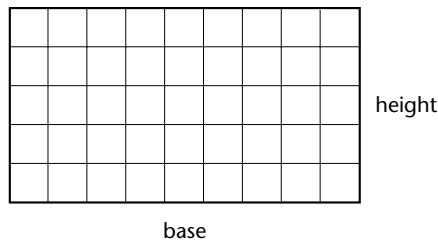

- Step 4: Complete the table below using the dimensions from your cut out rectangles. (The first row is filled out, using the example above.)

BASE	HEIGHT	AREA
9 units	5 units	$A = b \times h$ $A = 9 \times 5$ $A = 45 \text{ units}^2$
units	units	units <sup>2</sup>

- Step 5: Check the area by counting the number of squares in each rectangle.

## Thinking Space



Now let's create a formula for determining the area of triangles by using the method of folding a piece of paper in half.

If you've ever made a birthday card, you know that you start by folding a piece of paper in half.

If you unfold this card, you will see that you have created two identical rectangles, side by side.



Now try folding one of your paper rectangles in half to create two identical triangles.

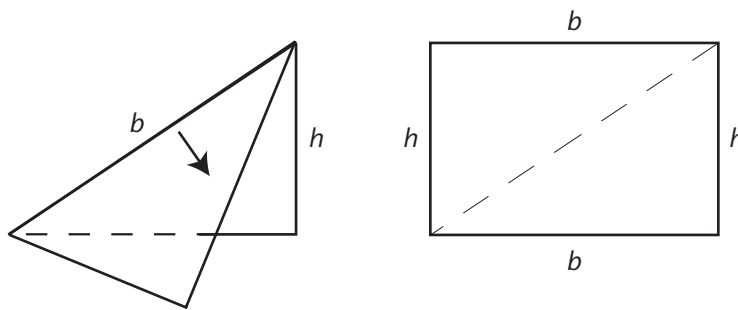

You'll find that one rectangle can make two triangles.

In the first table, you calculated the area of your paper rectangle. Can you guess the area of one of the triangles?



Check your guess by counting the number of complete squares in the triangle. Remember, two half squares = 1 square.

## Create a Formula to Determine the Area of Triangles

If the area of a rectangle is base  $\times$  height, then the area of the triangle must be half of that. You can calculate the area of a triangle by multiplying base  $\times$  height then dividing by 2.

Thinking Space

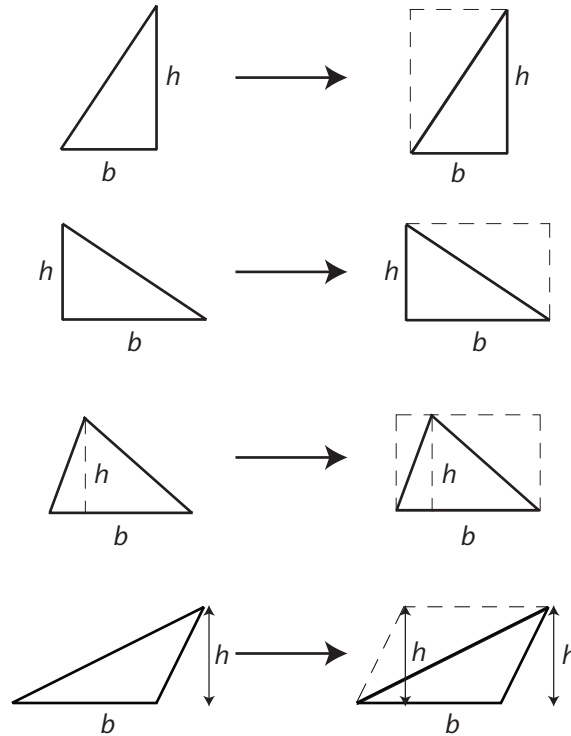

Area of a triangle = base multiplied by height divided by 2.

The same equation can be written as  $\frac{\text{base} \times \text{height}}{2}$ .

<p>Area of a triangle = <math>bh \div 2</math></p> <p>= <math>\frac{bh}{2}</math></p>
---

## Determining the Base and Height of a Triangle

Before you can calculate the area of a triangle, you need to determine the base and height of a triangle. This takes some practice. Here are some steps to follow which will make it easier for you.

- Step 1: Decide which side of the triangle will be your base. The base can be any side of the triangle.
- Step 2: Find the height of the triangle. Draw a perpendicular line from the base of the triangle to the vertex. With some triangles, the height of a triangle can be drawn outside the triangle.
- Step 3: Calculate the area using the base and height:  $\text{Area} = \frac{1}{2}bh$

Thinking Space

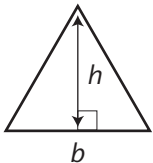
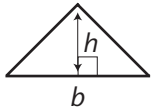
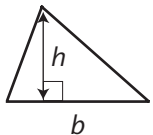
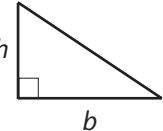
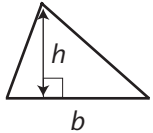
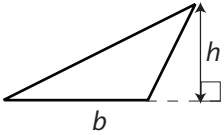
Equilateral Triangle	
Isosceles Triangle	
Scalene Triangle	
Right Triangle	
Acute Triangle	
Obtuse Triangle	



Here are two examples of calculating the area of a triangle:

1. Find the area of the following triangle.

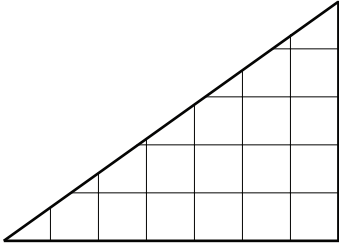

$$A = b \times h \div 2$$

$$A = 7 \times 5 \div 2$$

$$A = 35 \div 2$$

$$A = 17.5 \text{ units}^2$$

2. Find the area of the following triangle.

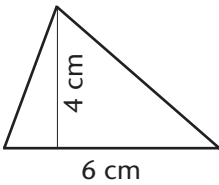

$$A = b \times h \div 2$$

$$A = 6 \times 4 \div 2$$

$$A = 24 \div 2$$

$$A = 12 \text{ cm}^2$$

Here's a tricky one: Can you take five toothpicks away from this figure to leave only five triangles?

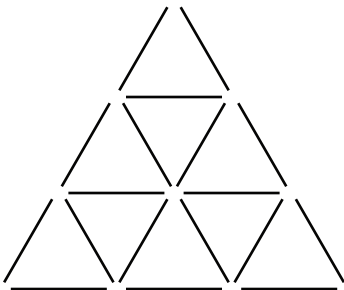

Thinking Space



## Practice

1. Fill in the missing numbers.

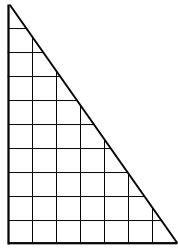

Base = \_\_\_\_\_ units

Height = \_\_\_\_\_ units

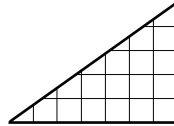

Base = \_\_\_\_\_ units

Height = \_\_\_\_\_ units

2. Find the area of each triangle. Include the units.

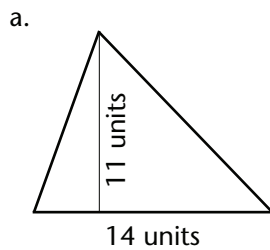

Area =

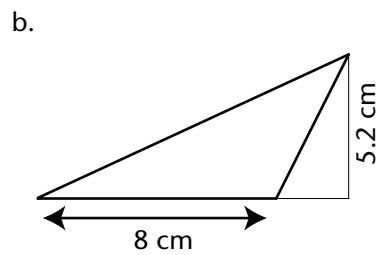

Area =

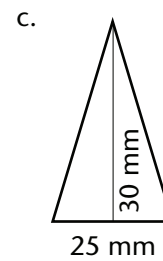

Area =

3. Find the area of each triangle. Include the units.  
*Hint: Make sure the units of the height and the base are the same before you find the area.*

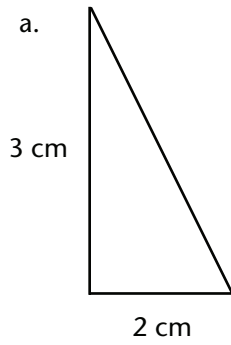

Area =

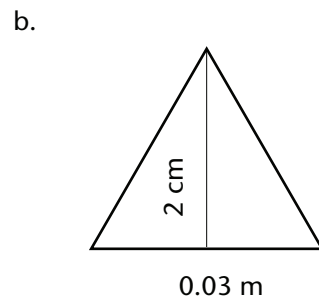

Area =

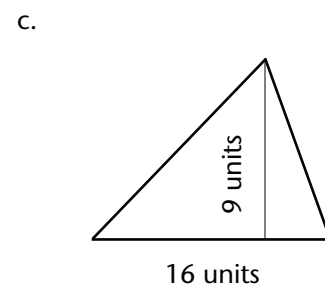

Area =

4. A triangle has a base of 6 m. The height is 4 m. Find the area of the triangle.

5. If line segment BC is the base of  $\triangle ABC$ , use a dotted line to show the height of this obtuse triangle. Then, calculate the area of the triangle.  
*Hint: The height can lie outside of the triangle*

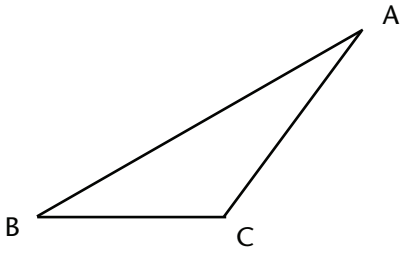

Turn to the Answer Key at the end of the Module and mark your answers.

## Lesson 3.2C: Finding the Area of Parallelograms

### Student Inquiry



This activity will help you get ready for, learn, and review the information in the upcoming lesson.

When you turn this page over, you will find a chart containing the inquiry outcomes for this lesson. You may be able to answer some of these questions already! Start by writing down your thoughts before the lesson.

When you finish the lesson, answer each question and give an example.

	BEFORE THE LESSON	AFTER THE LESSON
Student Inquiries	What I already know about this question:	What I thought at the end: My final answer, and examples:
How can I use the area of a rectangle to find the area of a parallelogram?		answer
Can I create a formula to determine the area of parallelograms?		example
		answer
		example

## Lesson 3.2C: Finding the Area of Parallelograms

### Introduction

Did you know that the square-shaped window in your house and the rectangular-shaped piece of paper in your book are both in the shape of a parallelogram? Parallelograms share similar properties to squares and rectangles. Build a rectangle with toothpicks and marshmallows.

If you push down on the top, it will tilt. The shape is no longer that of a rectangle, but it's still a parallelogram.

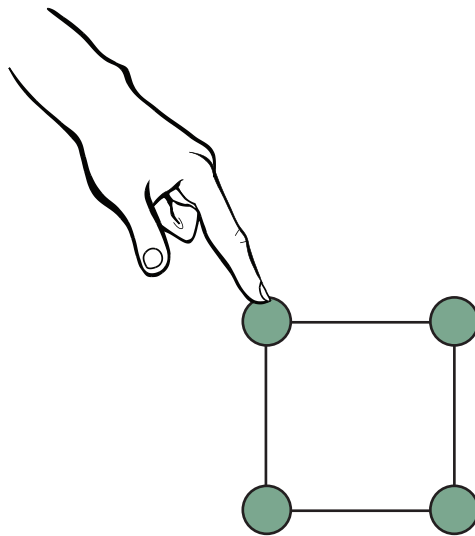

Does the area inside the toothpick rectangle change when you tilt it?

In this lesson, you will learn how to use the area of a rectangle to find the area of all parallelograms.

You'll need graph paper, scissors, pencil, and a ruler to complete the activities in this lesson.

Thinking Space





## Warm-up

First, let's review how to find the area of rectangles from the previous lesson. Remember square units are used to measure area.

In this rectangle, there are 4 groups of 2 square centimetres ( $4 \times 2$ ). You can find the area of this rectangle by multiplying base  $\times$  height.

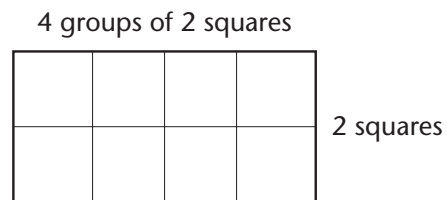
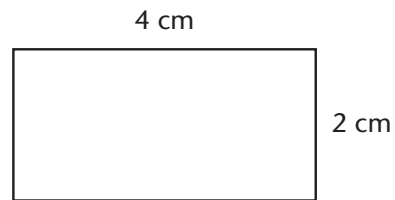

$$\begin{aligned}\text{Area} &= 4 \text{ squares} \times 2 \text{ squares} \\ &= 8 \text{ square units} \\ &= 8 \text{ units}^2\end{aligned}$$

$$\begin{aligned}\text{Area} &= 4 \text{ cm} \times 2 \text{ cm} \\ &= 8 \text{ cm}^2\end{aligned}$$

Thinking Space





## Explore

### What is a Parallelogram?

Compare these two figures.



Figure 1



Figure 2

How are they the same, and how are they different?

Compare these two figures.

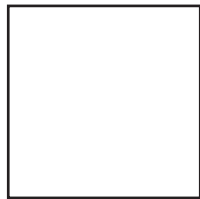

Figure 3

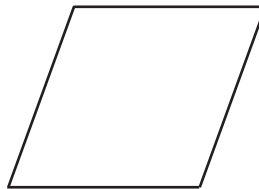

Figure 4

How are they the same, and how are they different?

All four figures are parallelograms, but have different names.

Figure 1 is a rectangle.

Figure 2 is a parallelogram.

Figure 3 is a square.

Figure 4 is a rhombus.

Thinking Space



A **parallelogram** is a four-sided shape with opposite sides parallel and equal in length.

Parallelograms with special names:

Square—all sides are equal and all angles are  $90^\circ$ .

Rectangle—opposite sides are equal and all angles are  $90^\circ$ .

Rhombus—all sides are equal and opposite sides are parallel.

## Parallelograms and Rectangles

To do this activity you will need:

- scissors
- graph paper
- pencil

Step 1: Draw a rectangle on graph paper, then cut it out.



Step 2: What is the area of your rectangle? There are two ways to determine the area.

1. You could count all of the squares to figure out the area.
2. You could also count the number of squares along the base of the rectangle and the number of square along its height. Multiply base  $\times$  height to get the area.

Are both of your answers the same?

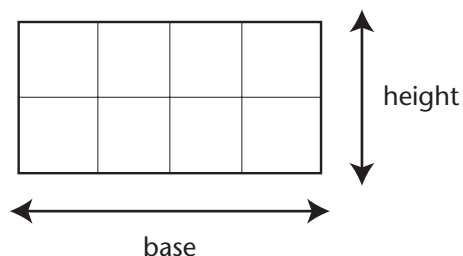

Thinking Space



Step 3: Draw a parallelogram on graph paper, then cut it out.

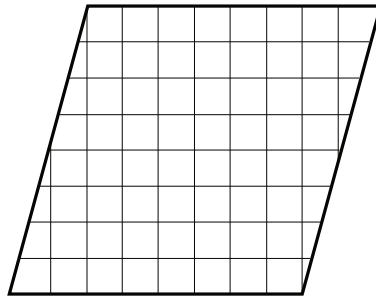

Step 4: Count the squares in your parallelogram to determine the area.

Do you think your answer is accurate? What was your strategy for counting the pieces of squares?



Step 5: Cut off the triangle at the left side of your parallelogram.

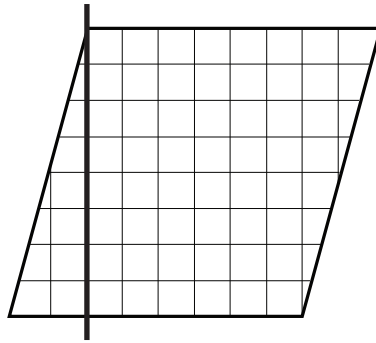

Step 6: Move the triangle you cut off to the right side of your parallelogram. Now you have a rectangle! You know how to find the area of a rectangle.

What is the area of this rectangle? Is your answer the same as your answer in Step 4?

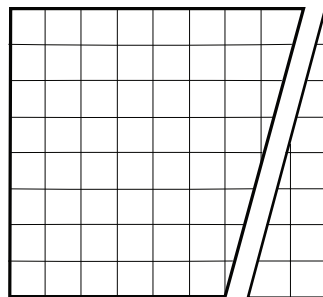

Repeat Steps 4, 5, and 6 a few more times with parallelograms of different sizes.

Thinking Space

## Create a Formula to Determine the Area of Parallelograms

The formula you use to find the area of each rectangle is:

Area of a rectangle = base  $\times$  height

In your thinking space, can you write a formula to find the area of a parallelogram?

Did you guess that the formula to find the area of a parallelogram is the same as the formula to find the area of rectangles?

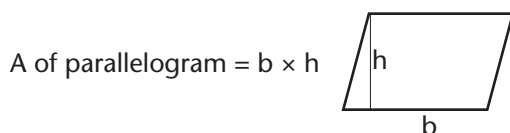
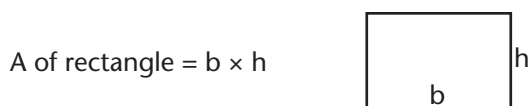

Area of a parallelogram = base  $\times$  height

Be Careful: The height is NOT the length of the slanted side! The height is where the dotted line would be if you cut off the end of the parallelogram to make a rectangle.

height  $\perp$  base

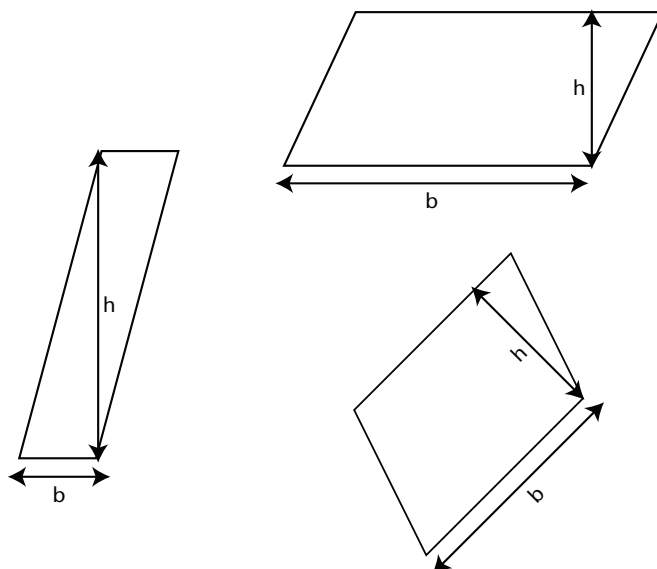

Thinking Space



*I saw that symbol in Lesson 3.1A. It means perpendicular. The height is perpendicular to the base.*

Example 1:

The parallelogram below has a base of 4 units and a height of 3 units.  
Calculate the area using the formula

Thinking Space

$$\text{Area} = \text{base} \times \text{height}.$$

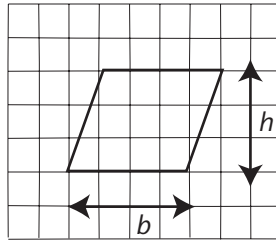

Here's the answer:

$$\text{Area} = 4 \text{ units} \times 3 \text{ units}$$

$$\text{Area} = 12 \text{ square units}$$

The area of the parallelogram is 12 units<sup>2</sup>.

Example 2:

Try this one.

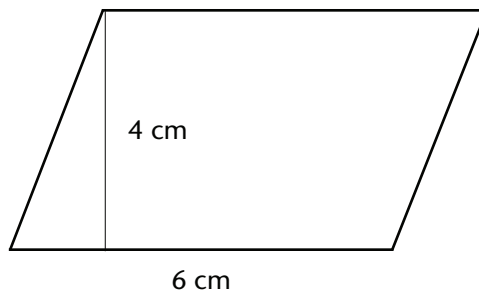

$$\text{base} = \underline{\hspace{2cm}} \text{ cm}$$

$$\text{height} = \underline{\hspace{2cm}} \text{ cm}$$

$$A = b \times h$$

$$A = \underline{\hspace{2cm}} \text{ square cm}$$

Example 3:

Look at the following parallelograms. In your thinking space, determine the height and base of each parallelogram. Then find the area of each parallelogram.

Thinking Space

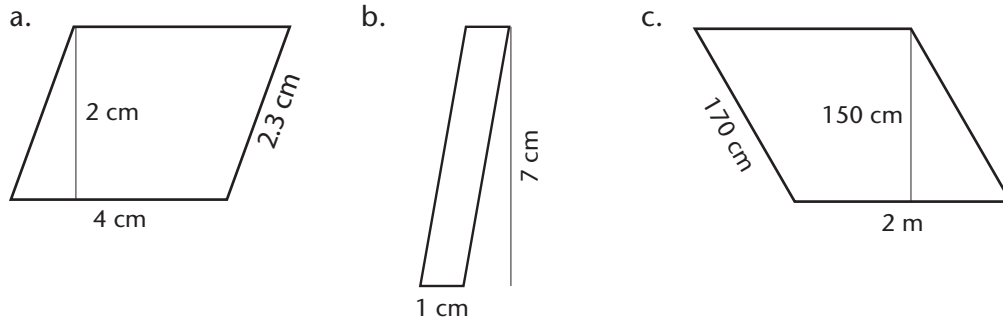

Did you get these answers? Once you're comfortable with parallelograms, try the Practice.

	BASE	HEIGHT	AREA
a.	4 cm	2 cm	8 cm <sup>2</sup>
b.	1 cm	7 cm	7 cm <sup>2</sup>
c.	2 m	150 cm	3 m <sup>2</sup>



## Practice

1. Find the area of the parallelogram below:

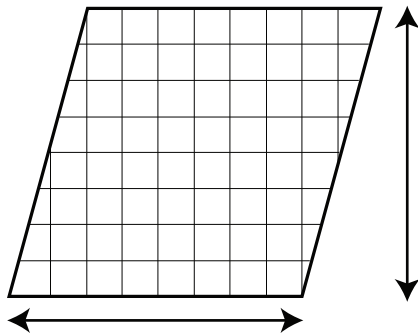

base = \_\_\_\_\_ units

height = \_\_\_\_\_ units

Area =  $b \times h$

= \_\_\_\_\_ units  $\times$  \_\_\_\_\_ units

= \_\_\_\_\_  $\text{units}^2$

2. Find the area of the parallelograms below:

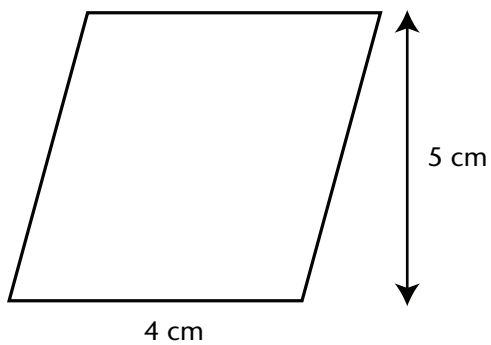

Area =  $b \times h$

= \_\_\_\_\_ cm  $\times$  \_\_\_\_\_ cm

= \_\_\_\_\_  $\text{cm}^2$



Area = \_\_\_\_\_  $\times$  \_\_\_\_\_

= \_\_\_\_\_  $^2$

3. Find the area of the parallelograms below:

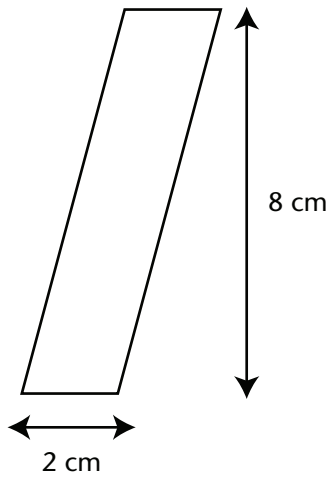

base = \_\_\_\_\_

height = \_\_\_\_\_

Area = \_\_\_\_\_

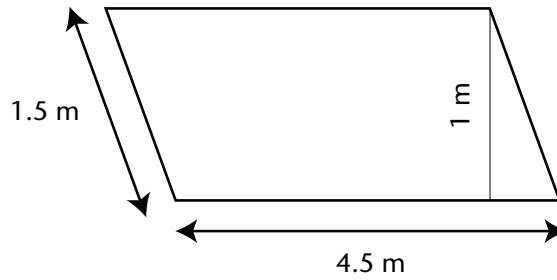

base = \_\_\_\_\_

height = \_\_\_\_\_

Area = \_\_\_\_\_

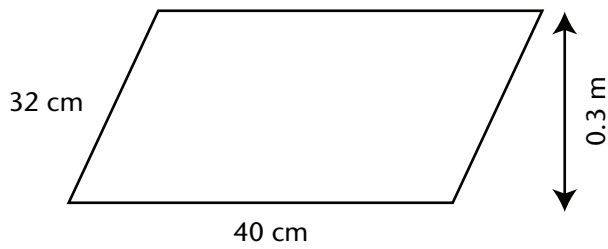

base = \_\_\_\_\_

height = \_\_\_\_\_

Area = \_\_\_\_\_



4. Complete the following table. Round your answer when necessary.

BASE	HEIGHT	AREA
125 m	25 m	
36 cm	18 cm	
10.2 m	8.4 m	
0.25 m	4.93 cm	
7 cm		49 cm <sup>2</sup>
	3.6 m	7.2 m <sup>2</sup>



Turn to the Answer Key at the end of the Module and mark your answers.



## Lesson 3.2D: Problem Solving with Area

### Student Inquiry



This activity will help you get ready for, learn, and review the information in the upcoming lesson.

When you turn this page over, you will find a chart containing the inquiry outcomes for this lesson. You may be able to answer some of these questions already! Start by writing down your thoughts before the lesson.

When you finish the lesson, answer each question and give an example.

	BEFORE THE LESSON	AFTER THE LESSON
Student Inquiries	What I already know about this question:	What I thought at the end: My final answer, and examples:
What kinds of problems involve finding the area of triangles?		answer
		example
What kinds of problems involve finding the area of parallelograms?		answer
		example
What strategies can I use to solve problems involving area?		answer
		example

## Lesson 3.2D: Problem Solving with Area

### Introduction

The Ancient Egyptians built the Great Pyramid around 5000 years ago. The Egyptian builders didn't have the tools that we have today, yet they were still able to build one of the most spectacular buildings in the world. Engineers are still trying to figure out how they did it. Did you know that the builders oriented the pyramid so that the four corners point almost perfectly north, south, east, and west? Incredibly, they used around 2.3 million stone blocks, weighing an average of 2.5 to 15 tons each, to build the structure. Engineers estimate that the builders would have had to set a block in place every two and a half minutes in order to complete the massive structure.

To build the Great Pyramid, the Ancient Egyptians must have had a step-by-step plan figured out, and a system in which to carry out their plan. The pyramid is proof of how effective they were at solving math problems to meet their practical needs, such as surveying land and building temples. How do you think they were able to come up with such a plan and carry it out?

In this lesson, you will learn the steps involved to understand a problem involving area, make a plan to solve it, and carry out the plan.

Thinking Space





## Warm-up

Imagine you are asked to build a pyramid. What are some of the things you would have to think about in making up a plan? For example, can you start putting stones in place right away, or do you have to first think about what your pyramid should look like? Can you use metal or clay to build your pyramid? In your thinking space, write down some of the things you need to plan before you start actually building a pyramid.

You can also use a web to brainstorm some ideas. Start by writing, “Make a plan to build a pyramid” in the centre of the web. What step would be first in your plan? *Hint: you will certainly need to choose the length of the base of the pyramid.*

You can use different strategies to solve a math problem. It is more important to remember that math problems generally can’t be solved in one step. You have to start at the beginning, use what you know, and work your way through steps to arrive at the answer.

Here are some steps the Ancient Egyptians might have followed to build the Great Pyramid:

1. Thought about what they wanted to do.
2. Brainstormed ideas.
3. Designed a picture of a pyramid on papyrus paper, using tools such as a ruler and compass.
4. Figured out the dimensions of the pyramid, and the exact measurements of the base and height.
5. Studied their design and considered any math problems related to building it.
6. Solved math problems related to area.
7. Calculated how much material they would need and the cost involved.
8. Gathered materials and necessary tools.
9. Laid down the first layer of stones to make a foundation.

Thinking Space



10. Checked that the foundation was perfectly level. The foundation needed to support the whole structure, so it must have been designed to be perfectly level, and able to support the enormous weight without sinking.
11. Continued to build until the pyramid was complete.

The Great Pyramid we see today is the product of their well-thought out plan! It is interesting that the Egyptians chose the triangle for their design. Maybe they liked the strong qualities of a triangle.

Thinking Space





## Explore

In Module 1, you learned how to solve problems involving the addition of integers by working your way through a series of steps:

- Step 1: Understand the problem: What information am I given?
- Step 2: Make a plan to solve the problem: How can I use the information to solve the problem?
- Step 3: Carry out the plan to solve the problem.
- Step 4: Answer the question asked.

Instead of using these steps to add integers, how can you use them to solve problems with area?

### Example 1:

Tim has cleared some farmland in the shape of a parallelogram. He would like to plant flax seed on his field. The seed costs \$0.50 per square metre. Tim is willing to spend \$100 but is worried that the seed might be too expensive. He measured his field and determined that the base is 21 m and a height is 9 m. Can Tim buy the flax seed with \$100 or is it too expensive?

#### Step 1: Understand the problem.

Highlight the clue words:

Tim has **cleared some farmland** in the shape of a **parallelogram**. He would like to **plant flax seed** on his field but the **seed costs \$0.50 per square metre**. Tim is **willing to spend \$100** but is worried that the seed might be too expensive. He measured his field, and determined that the **base is 21 m** and a **height is 9 m**. Can Tim buy the flax seed with \$100, or will it cost more than \$100 to plant the area of farmland?

## Thinking Space





Draw a picture:

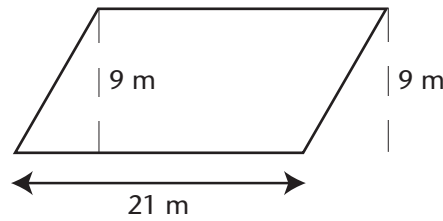

Underline the questions:

Can Tim buy the flax seed with \$100, or will it cost more than \$100 to plant the area of farmland?

**Step 2: Make a plan.**

Consider units:

In this case, both base and height are in metres.

Determine which side will be the base:

In this case, base and height are given.

Decide on how many parts you need to solve in the problem:

This is a three-part question:

1. I need to find the area of the field.
2. I need to find the cost of planting the flax seed.
3. I need to decide if it is more or less than \$100.

Thinking Space

**Step 3: Carry out the plan.**

Part 1: Write the equation.

Area of a parallelogram = base  $\times$  height (bh).

$$\text{Area} = 21 \times 9$$

$$\text{Area} = 189 \text{ m}^2$$

Part 2: The seed is \$0.50 per square metre, so the cost will be the area of the field multiplied by \$0.50.

$$\text{Cost} = 189 \times 0.5 = \$94.50$$

Part 3: The cost of \$94.50 is less than \$100, so Tim will be able to plant his field.

**Step 4: Answer the questions asked.**

Can Tim buy the flax seed with \$100, or will it cost more than \$100 to plant the area of farmland?

Answer: Yes, Tim can purchase the flax seed and plant his field.

**Example 2:**

Robyn has dug out a garden in the shape of a triangle. She wants to plant as many daffodils as she can. The base of the garden is 240 cm and the height is 3.5 m. She knows that she can plant 35 daffodils per square metre of garden. How many daffodils can she plant?

**Step 1: Understand the problem.**

Highlight the clue words:

Robyn has dug out a garden in the shape of a triangle. She wants to plant as many daffodils as she can. The base of the garden is 240 cm and the height is 3.5 m. She knows that she can plant 35 daffodils per square metre of garden. How many daffodils can Robyn plant in her garden?

Draw a picture:

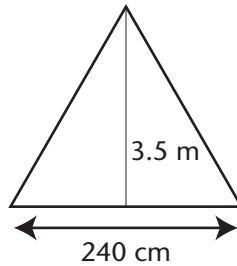

Underline the questions:

How many daffodils can she plant in that area of garden?

**Step 2: Make a plan.**

Consider units:

$$\text{Base} = 240 \text{ cm}$$

$$\text{Height} = 3.5 \text{ m}$$

Convert base to metres:

$$240 \text{ divided by } 100 = 2.4 \text{ m, or}$$

$$3.5 \text{ m multiplied by } 100 = 350 \text{ cm}$$

Let's use  $b = 2.4 \text{ m}$  and  $h = 3.5 \text{ m}$ .

Determine which side will be the base:

Base and height are given.

Decide on how many parts you need to solve in the problem:

Okay, this is a two-part question:

1. I need to find the area of the garden.
2. I need to find the number of daffodils I can plant in that area.

**Step 3: Carry out the plan.**

Write the equation:

$$\text{Part 1: Area of a triangle} = \text{base} \times \text{height} \div 2$$

$$\text{Area} = (2.4 \times 3.5) \div 2$$

$$\text{Area} = 8.4 \div 2$$

$$\text{Area} = 4.2 \text{ m}^2$$

Part 2: 38 daffodils can be planted per square metre.

$$\# \text{ of daffodils} = 35 \times 4.2$$

$$\# \text{ of daffodils} = 147 \text{ daffodils}$$

**Step 4: Answer the questions asked.**

How many daffodils can Robyn plant in her garden?

Answer: Robyn can plant 147 daffodils in her garden.

Thinking Space



## Practice

1. Nick makes a rectangular sign that measures  $30\text{ cm} \times 60\text{ cm}$ . He wants to attach a border that measures  $50\text{ cm} \times 80\text{ cm}$ . What is the area of the border around the poster?

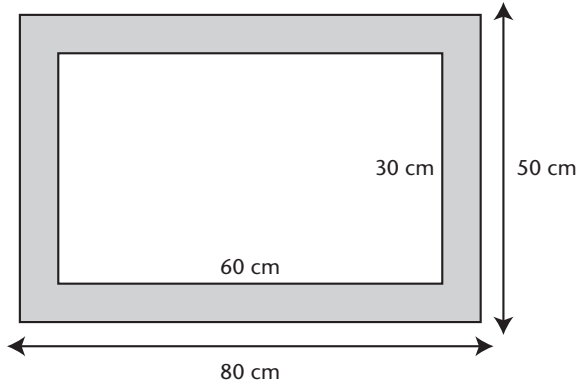

2. Mike wants to make a poster, and has chosen a rectangular piece of paper to use. He accidentally knocks over a bottle of paint that spills all over the corner of the paper. He will need to cut it off before starting. The poster now looks like the figure below. What is the area of the poster?

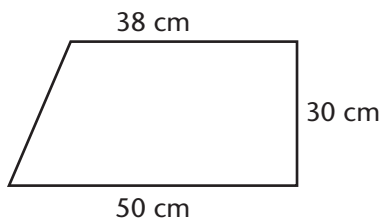

3. Wendy wants to build a patio covered with mosaic tiles. The patio is in the shape of a parallelogram, as shown below. The height will be 4 m and the base 300 cm. Wendy can buy 8 mosaic tiles per square metre. The cost of each tile is \$0.50. How many tiles will Wendy use to cover her patio? How much will the tiles cost in total?

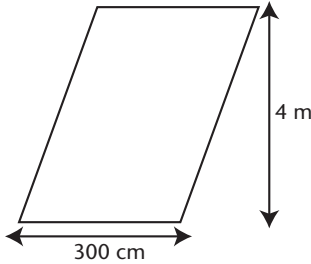

4. Robyn has dug out a garden in the shape of a triangle to plant daffodils. The height of her garden is 3.5 m. She wants to build a pathway along the side of her triangular shaped garden as shown below. She has enough pebbles to fill in  $4.2 \text{ m}^2$  for a pathway. What is the base of the pathway?

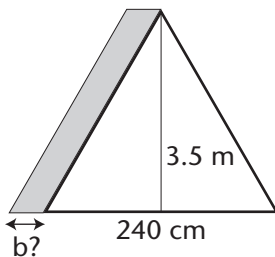

Turn to the Answer Key at the end of the Module and mark your answers.





## Section Summary

In this section, you learned how to measure things. You also discovered how to find the area of a triangle and a parallelogram. Applying these new skills in finding the areas of polygons, you were able to follow steps to solve problems involving area.

### Units of Length

10 millimetres (mm) = 1 centimetre (cm)

10 cm = 1 decimetre (dm)

100 cm = 1 metre (m)

1000 m = 1 kilometre (km)

### Determining the Base and Height of Triangles

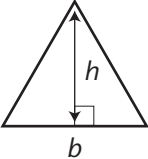
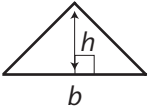
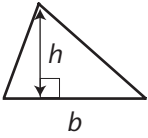
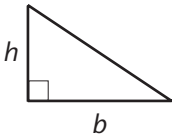
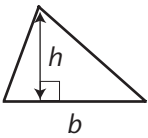
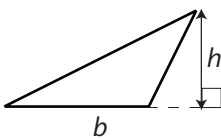
Equilateral Triangle	
Isosceles Triangle	
Scalene Triangle	
Right Triangle	
Acute Triangle	
Obtuse Triangle	

## Finding the Area of a Triangle

$$\text{Area of a triangle} = bh \div 2$$

## Finding the Area of a Parallelogram

1. Any side of a parallelogram can be the base.
2. The height of a parallelogram is a perpendicular line drawn from the base to the opposite side.
3. The height can sometimes be drawn outside the parallelogram.

Here is an example of determining the base and height of a parallelogram:

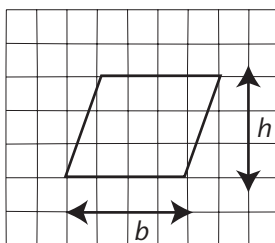

$$\text{Area of a parallelogram} = b \times h$$

## Using Steps to Solve Problems with Area

### Step 1: Understand the problem.

Highlight the clue words:

- Determine if height and base are given.
- Determine what information is important to help you solve the problem and what is not. Eg. Side length is not needed to solve the area of a parallelogram or triangle.

Draw a picture:

- It always helps to draw a picture so you can see what you are trying to do.

Underline the questions:

- Figure out exactly what you are being asked. For example, are you being asked to find the length of the base or the area of a triangle?

**Step 2: Make a plan.**

Consider units:

- Determine if the height and base are in the same unit.
- If the units are different, you will have to convert the units of one to the other. For example, if height is in centimetres and base is in metres, convert the base to centimetres by multiplying by 100, or convert the height to metres by dividing by 100.

Determine which side will be the base.

Decide how many parts the problem asks you to solve.

**Step 3: Carry out the plan.**

Write the equation:

- Area of a parallelogram = base  $\times$  height ( $bh$ )
- Area of a triangle =  $\frac{1}{2} \times$  base  $\times$  height ( $\frac{1}{2}bh$ )

Solve equation.

**Step 4: Answer the questions asked.**



## Section Challenge

The local recycling centre has asked you to design a poster for them. Part of the challenge is to use the least amount of paper. The recycling centre has a saying, "less is more!" They would like the poster to be in the shape of one of the triangles or parallelograms shown below. Can you choose the shape that would use the least amount of paper?

Instructions are provided for you here, as well as space to complete your work. Feel free to use your own paper if you need more space. *Note: To solve this problem, you can follow the steps in the Section 2 Summary.*

The local recycling centre has asked you to design a poster for them. Part of the challenge is to use the least amount of paper. The recycling centre has a saying, "less is more!" They would like the poster to be in the shape of one of the triangles or parallelograms shown below. Choose the shape that would use the least amount of paper. To get full marks for this question, you need to show your work for calculating the area of each shape.

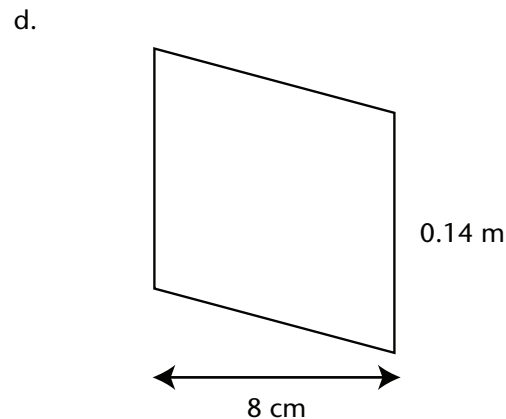
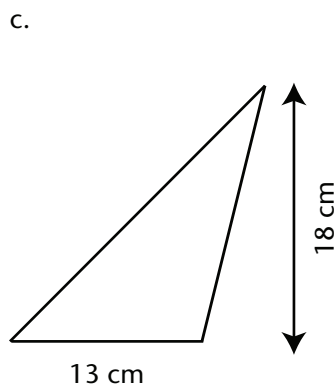
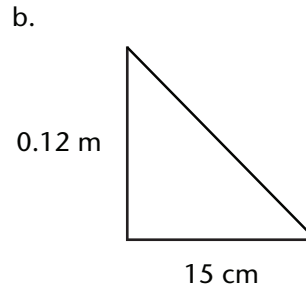
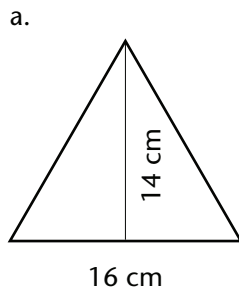



## Section 3.3: Circles

# Section 3

### Contents at a Glance

Pretest	167
Section Challenge	172
Lesson A: What's in a Circle?	173
Lesson B: What is Pi?	187
Lesson C: Circumference of a Circle	197
Lesson D: Area of a Circle	211
Section Summary	225

### Learning Outcomes

By the end of this section you will be better able to:

- identify the components and characteristics of circles.
- describe the relationships between the parts of a circle.
- construct circles using geometric tools.
- apply a formula to find the circumference and area of a circle.
- solve problems that involve finding the circumference or area of a circle.
- solve problems involving the area of triangles, parallelograms, and/or circles.





## Pretest 3.3

Complete this pretest if you think that you already have a strong grasp of the topics and concepts covered in this section. Mark your answers using the key found at the end of the module.

If you get all the answers correct (100%), you may decide that you can omit the lesson activities.

1. Fill in the blanks:

- a. The \_\_\_\_\_ is a point inside a circle from which all points on the circumference are the same distance.
- b. The \_\_\_\_\_ is the longest chord that can be drawn inside a circle.
- c. The diameter is \_\_\_\_\_ times as large as the radius.
- d. The \_\_\_\_\_ is the distance around the circle.
- e. A diameter is a line segment drawn from one point on a circle to another point that passes through the \_\_\_\_\_.
- f. Every point on the circumference is at an \_\_\_\_\_ distance from the center of the circle.
- g. The \_\_\_\_\_ divides a circle in half.

2. Draw a circle with a radius of 2 cm.

3. Draw a circle with a diameter of 5 cm.

4. Determine the diameter of each circle with a given radius:

a.  $r = 3.0$  cm

b.  $r = 4.6$  m

5. Determine the radius of each circle with a given diameter:

a.  $d = 4.0$  m

b.  $d = 12.4$  cm

6. Determine the circumference of a circle with each diameter.  
Give your answer to the nearest tenth.

a.  $d = 10.0$  cm

b.  $d = 6.7$  m

7. Determine the circumference of a circle with each radius.  
Give your answer to the nearest tenth.

a.  $r = 5.0$  cm

b.  $r = 2.3$  m

8. A goldfish swims around a circular pond 4 times. The pond has a diameter of 2.0 meters. Approximately how far does the fish swim in total?  
Your answer should be rounded to one decimal place.

9. What is the area of each circle?

a.  $r = 4.0$  cm

b.  $d = 6.0$  m

10. A music CD has an outside diameter of 12 cm and an inside diameter of 2 cm. What is the area of the label that would fit onto the music CD?

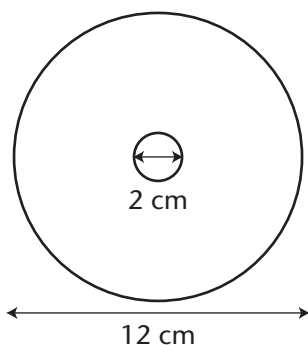

11. A car wheel has a diameter of 50 cm. If the car wheel makes 1000 rotations, how many metres will the car have travelled?



Turn to the Answer Key at the end of the Module and mark your answers.

## Section Challenge

Imagine you have a circular mirror hanging on your wall. Accidentally, you knock it off the wall and it falls to the ground and cracks. The wooden rim that holds the mirror in place also breaks. Oh no! What can you do?

You want to replace the mirror, so you get out your measuring tape and measure the diameter of the mirror and the diameter of the rim. Luckily, both the mirror and rim hold together well enough so that you can measure the diameter of both.

When you get to the store and ask for help from the person at the service counter, they ask for the area of both the mirror and rim. The store can replace the mirror and rim if you can provide the area. The person at the counter gives you a pencil, paper, and calculator.

In this section, you will learn how to find the radius, diameter, and circumference of a circle. You will also learn how to determine the area of a circle and be able to provide the area of both the mirror and rim.

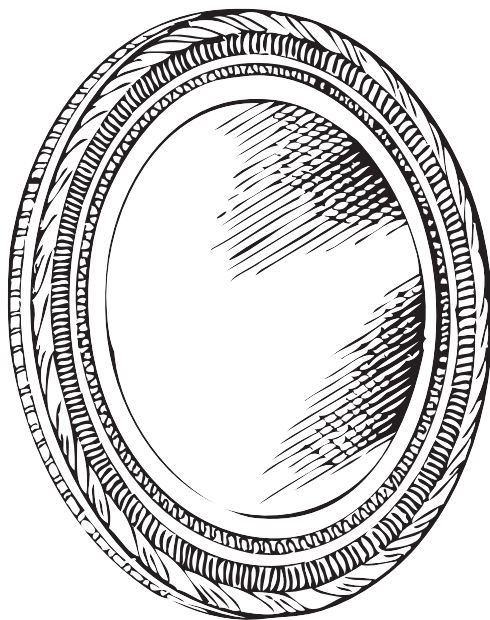

If you're not sure how to solve the problem now, don't worry. You'll learn all the skills you need to solve the problem in this section. Give it a try now, or wait until the end of the section—it's up to you!

## Lesson 3.3A: What's in a Circle?

### Student Inquiry



This activity will help you get ready for, learn, and review the information in the upcoming lesson.

When you turn this page over, you will find a chart containing the inquiry outcomes for this lesson. You may be able to answer some of these questions already! Start by writing down your thoughts before the lesson.

When you finish the lesson, answer each question and give an example.

	BEFORE THE LESSON	AFTER THE LESSON
<p>Student Inquiries</p> <p>How are the diameter and radius of a circle calculated?</p>	<p>What I already know about this question:</p>	<p>What I thought at the end: My final answer, and examples:</p> <p>answer</p> <p>example</p>
<p>How do I draw a circle with a given radius or diameter with a compass?</p>		<p>answer</p> <p>example</p>



## Lesson 3.3A: What's in a Circle?

### Introduction

Circles are everywhere around you. Look around and see how many objects are in the shape of a circle. Dinner plates, bicycle tires, and clocks are all made in the shape of a circle. Or how about looking at the centre of a daisy—it is circular. Circles are considered the perfect shape and have great significance in math, science, nature, culture, and art.

In many cultures, the circle represents the cycle of life as well as peace and harmony. After all, the Earth and Sun are both circular in shape. The circle is used to show that everything is connected. The circular medicine wheel and dream-catcher have healing significance to First Nations cultures. The circular yin-yang symbol represents balance in Chinese culture.

A long time ago, you couldn't use a clock to tell time; you had to use a sundial and the moving shadow of the sun. The sundial was designed and built based on the angles of a circle.

In this lesson, you will learn more about circles and how to draw them. You will also learn about the angles within a circle. Good luck!

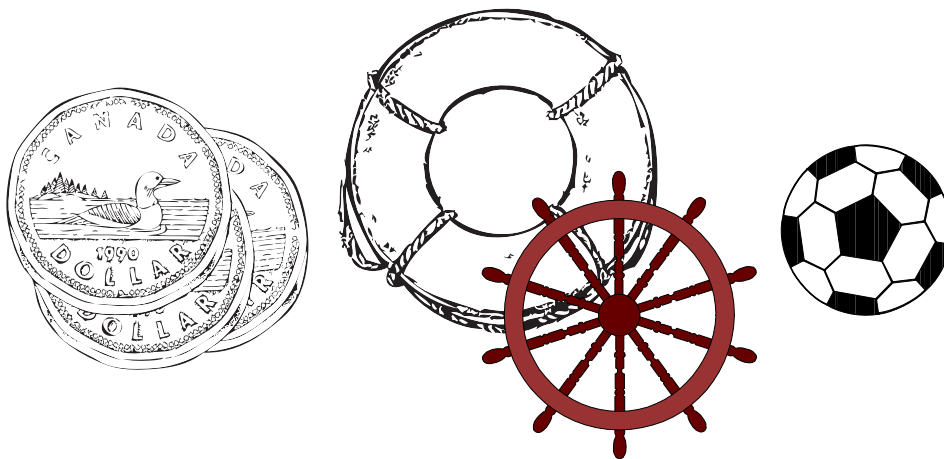

### Explore Online



Looking for more practice or just want to play some fun games? If you have internet access, go to the Math 7 website at:

<http://www.openschool.bc.ca/courses/math/math7/mod3.html>

Look for *Lesson 3.3A: What's in a Circle?* and check out some of the links!

### Thinking Space



Do you have any questions about how a sundial works?



## Warm-up

Look around you and see if you can spot circular shapes. Can you think of anything that is in the shape of a circle? Remember circles come in many forms: spheres (eg. Earth, bouncy balls), discs (eg. dinner plates), spirals (eg. snail shells), cylinders (eg. soup cans), cones (eg. ice cream cones) and domes (eg. igloos). In your thinking space, list three circles that you see.

What are some of the things that you know about circles? For example, a circle has no corners. Using the web below, write down everything you know about circles.

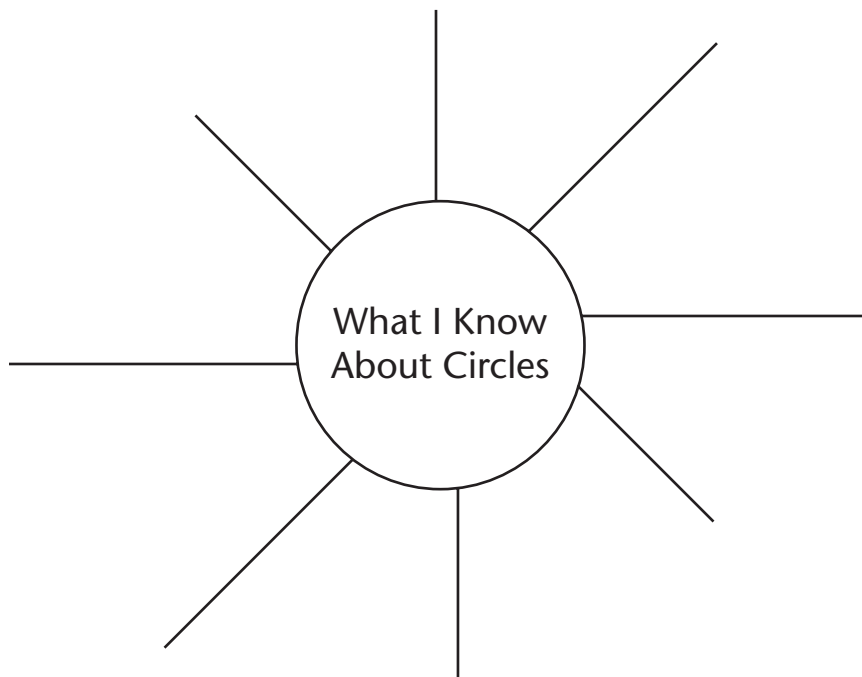



Thinking Space



Can you think of any similarities and differences between a polygon and a circle? Write down one similarity and one difference in your thinking space. Drawing a picture might help.

Thinking Space

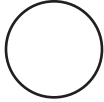

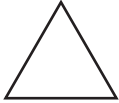
CIRCLES VS. POLYGONS		
	Similarities	Differences
    	<ul style="list-style-type: none"> <li>• They are both closed plane figures.</li> <li>• They are both geometrical shapes.</li> </ul>	<ul style="list-style-type: none"> <li>• A circle is round and has no corners.</li> <li>• A polygon is constructed of straight sides.</li> <li>• Connecting points with line segments make polygons.</li> <li>• Drawing a curve that is always equal distance from a centre point makes a circle.</li> <li>• Polygons are labelled with beginning to end points.</li> <li>• Circles have no beginning and no end.</li> </ul>



# Explore

Here's some circle vocabulary you'll need for this section:

TERM	DEFINITION	ILLUSTRATION
Centre	the given point inside a circle from which all points on the edge of the circle are the same.	
Radius	the length of a line segment drawn from the centre point to a point on the circumference.	
Radii	plural form of radius, or more than one radius.	
Chord	a line segment drawn from one point to another point on the circumference.	
Diameter	a line segment drawn from one point on a circle to another point that passes through the centre. The diameter is the longest chord that can be drawn within a circle. It also divides a circle in half.	
Circumference	distance around the circle.	
Arc	a part of the curve of the circle.	
Equidistant	equal distances. Every point on the circle is equidistant from the centre of the circle. Therefore, all radii within a given circle are the same length.	
Central angle	an angle formed by two radii of a circle. The vertex of the angle is at the centre point of the circle.	

## Using a compass to draw a circle with a given radius

Imagine that there is a drawing contest for an upcoming Winter Olympics. The contest involves drawing a poster that highlights the Olympic Rings. You want to make sure that each circle is the exact same size for the poster. You try and draw some circles freehand, but find that each circle is not perfectly round, and are all different sizes. You get a compass to draw the circles but are not sure how to use it to so that the radius of each circle is exactly 2 cm. Here are some steps to follow:

### How to Draw a Circle with a Compass

- Step 1: With your pencil and ruler, draw a line segment that is 2 cm in length.
- Step 2: Place the tip of the compass on one endpoint of the segment and its pencil on the other endpoint.
- Step 3: Hold the compass (tighten the compass thumbscrew) so that the distance between the point and the pencil doesn't change.
- Step 4: Put the point at the place where the center of the circle should be, and move the compass around to draw a circle.

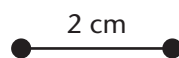

Using your compass, try drawing circles with radii: 2 cm, 3.5 cm, and 15 mm.

Thinking Space



## Using a Compass to Draw a Circle with a Given Diameter

The diameter of a circle is a line segment drawn from one point on a circle to another point that passes through the centre. The diameter has three important points (edge – circle – edge). It starts at the edge of the circle, passes through the centre, and ends at the edge of the circle.

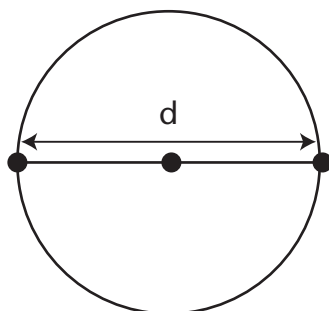

If the radius is the distance from the centre to the circumference, how much longer is the diameter compared to the radius?

In your thinking space, draw a circle with a radius of 2cm. Using your ruler, draw a line segment from one point on the circumference to another point that passes through the centre. Measure the diameter. How much longer is it than the radius?

You should have measured the diameter as 4 cm. The diameter is always twice the length of the radius. If you know the radius, you can multiply it by 2 to get the diameter.

$$\text{Diameter} = \text{Radius} \times 2$$

How do you calculate the radius if you know the diameter of a circle?

Look at the following circle; it has a diameter of 3.0 cm. How long is the radius? Measure the radius with your ruler to confirm your answer.

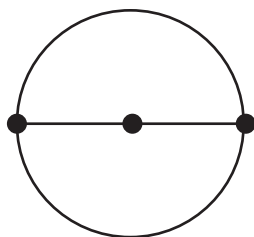

Thinking Space



You can also calculate the radius by using a formula.

$$\text{Radius} = \text{Diameter} \div 2$$

Answer:

$$\text{Radius} = \text{Diameter} \div 2$$

$$\text{Radius} = 3.0 \text{ cm} \div 2$$

$$\text{Radius} = 1.5 \text{ cm}$$

Let's draw a circle with a given diameter.

Step 1: Divide the given diameter by 2 to figure out the radius.  
(Example,  $3.0 \text{ cm} \div 2 = 1.5 \text{ cm}$ )

Step 2: Draw a line segment that is the length of the radius.

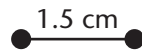

Step 3: Place the tip of the compass on one point of the line segment and your pencil on the other point.

Step 4: Hold the compass so that you won't change the distance between the compass point and the pencil when you draw the circle.

Step 5: Draw a circle.

Step 6: Measure the diameter with your ruler to confirm.

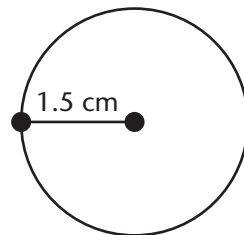

Thinking Space

## Drawing a Circle with a Rope

The Ancient Egyptians used a rope compass and straight edge to build the pyramids. A rope compass acts in the same way as the compass you find in your geometry set. The Egyptians would cut a piece of rope the same length as the radius of a given circle. A person (P1) would hold one end of the rope and stand still. The other person (P2) would rotate around the person and draw the circle (in the sand most likely). The distance from the person standing still (P1) and the person rotating around (P2) remains the same.

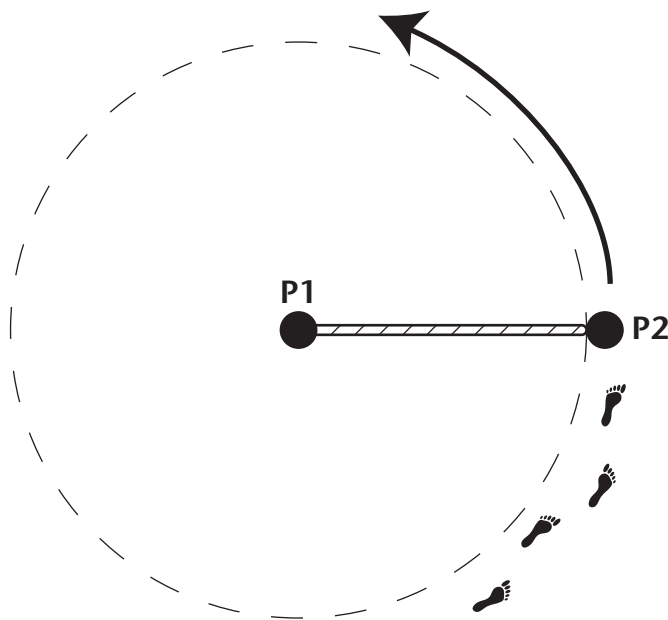

Here are the steps to follow: (do this activity on a workbench, corkboard, or cutting board—not your dining room table!)

1. Draw a line segment the length of the given radius.
2. Cut a piece of string (or rope) longer than the line segment.
3. Tie a loop at the end, so the remaining string or rope is the same length as the line segment. Put the pencil inside the loop.
4. Tie the other end of the string to a pushpin.
5. Push the pin into a piece of paper to act as the centre point.
6. Move the pencil away from the pin until the string is held tight between the pencil and pin.
7. Move your pencil around the pin to draw the circle, keeping the string tight.

Thinking Space





## Practice

1. Fill in the blanks:

- a. The \_\_\_\_\_ is a point inside a circle from which all points on the circumference are the same distance.
- b. The length of a line segment drawn from the centre point to a point on the circumference is called the \_\_\_\_\_.
- c. Radii = Plural form of \_\_\_\_\_.
- d. A line segment drawn from one point to another point on the circumference is called a \_\_\_\_\_.
- e. The \_\_\_\_\_ is the longest chord that can be drawn within a circle.
- f. The diameter is \_\_\_\_\_ times as long as the radius.
- g. The \_\_\_\_\_ is the distance around the circle.
- h. The diameter is a line segment drawn from one point on a circle to another point that passes through the \_\_\_\_\_.
- i. A part of the curve of the circle is called an \_\_\_\_\_.
- j. Every point on the circumference is at an \_\_\_\_\_ distance from the centre of the circle.
- k. The \_\_\_\_\_ divides a circle in half.

2. Draw a circle with a radius of 3 cm.

3. Draw a circle with a diameter of 4 cm.

4. Using your protractor, practise measuring the angles within each circle and fill in the following table.

Circle A:

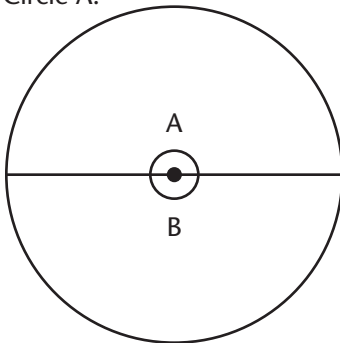

Circle B:

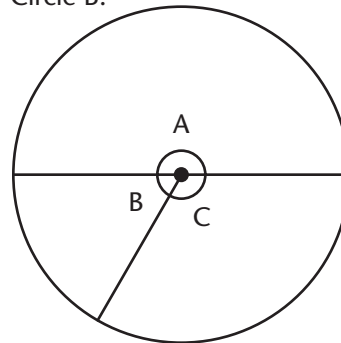

Circle C:

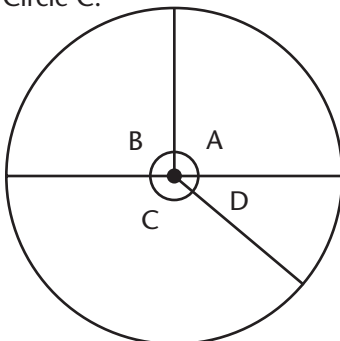

CIRCLE	ANGLES	SUM OF ANGLES
Circle A	$\angle A =$ _____ $\angle B =$ _____	$A + B =$
Circle B	$\angle A =$ _____ $\angle B =$ _____ $\angle C =$ _____	$A + B + C =$
Circle C	$\angle A =$ _____ $\angle B =$ _____ $\angle C =$ _____ $\angle D =$ _____	$A + B + C + D =$

5. Give the diameter for each circle.

a.  $r = 11$  cm

b.  $r = 6$  cm

c.  $r = 1.2$  cm

6. Give the radius for each circle.

a.  $d = 5 \text{ cm}$

b.  $d = 14 \text{ cm}$

c.  $d = 6.2 \text{ cm}$



Turn to the Answer Key at the end of the Module and mark your answers.

## Lesson 3.3B: What is Pi?

### Student Inquiry



This activity will help you get ready for, learn, and review the information in the upcoming lesson.

When you turn this page over, you will find a chart containing the inquiry outcomes for this lesson. You may be able to answer some of these questions already! Start by writing down your thoughts before the lesson.

When you finish the lesson, answer each question and give an example.

	BEFORE THE LESSON	AFTER THE LESSON
Student Inquiries	What I already know about this question:	What I thought at the end: My final answer, and examples:
What is the relationship between the circumference and the diameter of a circle?		answer
What is pi?		example
		answer
		example

## Lesson 3.3B: What is Pi?

Thinking Space

### Introduction

Since ancient times people have noticed that there is a relationship between the distance through the middle of a circle (its **diameter**) and the distance around a circle (its **circumference**).

Documents from as early as 240 B.C.E. tell us that Egyptian, Chinese, and Hindu mathematicians worked on the problem of defining this relationship.

In this lesson you will explore question of how diameter and circumference are related. You will be able to answer the question “What is pi?”



### Explore Online

Looking for more practice or just want to play some fun games?

If you have internet access, go to the Math 7 website at:

<http://www.openschool.bc.ca/courses/math/math7/mod3.html>

Look for *Lesson 3.3B: What is Pi?* and check out some of the links!



## Warm-up

In the second part of this lesson's activity you will be dividing numbers and rounding your answer.

Use your calculator to answer these division problems. Round your answer to two decimal places.

For example, when you ask your calculator to do:

$$51 \div 7$$

the answer it gives is:

$$7.2857143$$

You only want **two** decimal places in your answer. Look at the **third** decimal place. The number there is 5. You should round up at the **second** decimal place. Your rounded answer is:

$$7.29$$

Thinking Space



1.  $35 \div 8$  \_\_\_\_\_

2.  $18 \div 7$  \_\_\_\_\_

3.  $49 \div 13$  \_\_\_\_\_

4.  $183 \div 29$  \_\_\_\_\_

5.  $16.2 \div 9.5$  \_\_\_\_\_

6.  $371 \div 47.5$  \_\_\_\_\_

7.  $62 \div 12$  \_\_\_\_\_

8.  $2745 \div 87$  \_\_\_\_\_

9.  $1108 \div 6$  \_\_\_\_\_

10.  $38 \div 9$  \_\_\_\_\_



## Explore

Gather the supplies you will need for this lesson's activity.

- 3 circular objects (for example: a coffee mug, a soup can, a tealight candle)
- string that is long enough to go around the largest of your circular objects
- tape
- marker
- pencil
- ruler or measuring tape marked in centimetres
- paper

Step 1: Tape two pieces of paper together along the short side. Write the name of your first object on the top of the page. Use your ruler to draw a long straight line. Mark 0 at the left end of your number line.

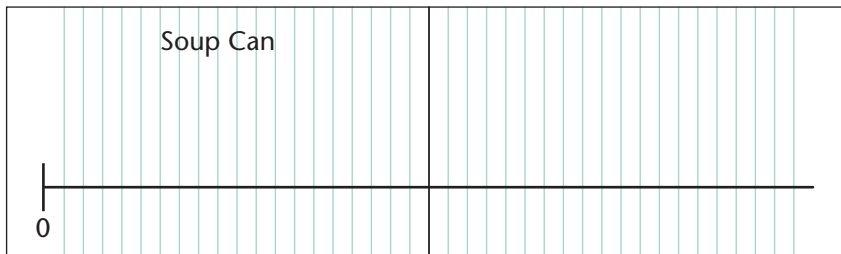

Step 2: Use the string to measure the diameter of one of your objects. Remember: Diameter is measured edge-centre-edge in a straight line. Use the marker to record the diameter of your object on the string.

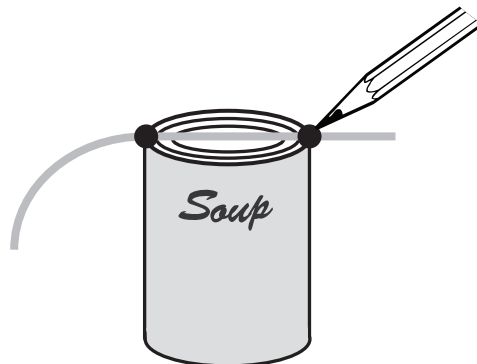

Thinking Space

**Step 3:** Transfer your measurement of the diameter to your number line. Hold one mark up to the "0" on your number line. Put "1" on your number line at the location of the second mark.

Mark "2", "3", and "4" on your number line in the same way. Attach a third piece of paper if you need a longer number line.

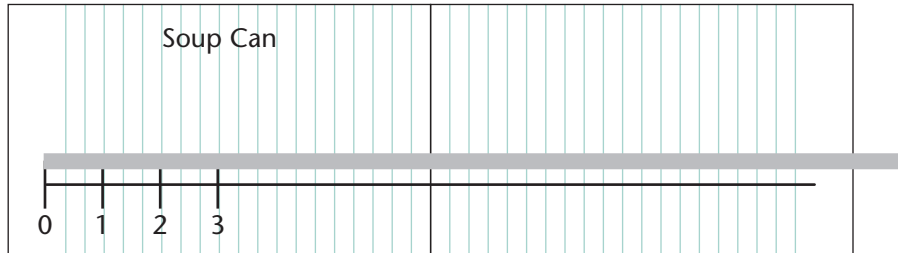

**Step 4:** Wrap the string around the same object and measure the circumference. Mark the string to show the circumference.



**Step 5:** Transfer your circumference measurement to the number line. Hold one mark up to the "0" on your number line. Put "\*" on your number line at the location of the second mark.

Get two more pieces of paper and do this activity again with your second object.

Get two more pieces of paper and do this activity one more time with your last object.

Arrange your three number lines so you can see all of them at once.

Do you notice something about the location of \* on each number line? It is always in the same place! Since \* is always in the same place, it has a special name.

It is  $\pi$ , the Greek letter "Pi".

The "2" on your number line shows the length of something that is 2 diameters long. The "4" on your number line shows the length of something that is 4 diameters long. The " $\pi$ " on your number line shows the length of something that is  $\pi$  diameters long.

Archimedes, Tsu Ch'ung-chih, Aryabhata, and other ancient mathematicians wanted to know the *exact* value of  $\pi$ ; its precise position on the number line. Is it close to  $3\frac{1}{4}$ ? Is it more than 3.1? A lot of people spent a lot of time trying to figure out the value of  $\pi$ . Some of the most well-known efforts are listed at the beginning of the next lesson.

Can you figure out a value for  $\pi$ ? Get a calculator.

Step 1: Look at the number line for your first object. Measure (in cm) the distance from "0" to "1" on your number line. This is the diameter of your first object. Record your measurement in the chart.

Step 2: Measure (in cm) the distance from "0" to "\*" on your number line.

This is the circumference of your object. Record your measurement in the chart.

Step 3: How many diameters are in one circumference? Use your calculator to divide circumference by diameter. Round your answer to two decimal places (just like you did in the warm-up).

This is your estimate for  $\pi$ . Record your estimate in the chart.

## Thinking Space



*That means the circumference is exactly  $\pi$  diameters long!*

Repeat these three steps with your other two numbers.

Were all of your estimates for  $\pi$  close to each other? Start the next lesson to find out how close you were to the actual value for  $\pi$ .

Thinking Space



## Lesson 3.3C: Circumference of a Circle

### Student Inquiry



This activity will help you get ready for, learn, and review the information in the upcoming lesson.

When you turn this page over, you will find a chart containing the inquiry outcomes for this lesson. You may be able to answer some of these questions already! Start by writing down your thoughts before the lesson.

When you finish the lesson, answer each question and give an example.

Student Inquiries	BEFORE THE LESSON		AFTER THE LESSON	
	What I already know about this question:		What I thought at the end: My final answer, and examples:	
What is the ratio of the circumference to the diameter for any circle?			answer	
			example	
Can I show that circumference divided by diameter (or $C \div d$ ) is approximately 3.14?			answer	
			example	
How can I solve problems involving circles using circumference, diameter, and radius?			answer	
			example	



## Lesson 3.3C: Circumference of a Circle

Thinking Space

### Introduction

In the last lesson, you discovered that the ratio of the circumference to the diameter of a circle is approximately 3:1. It didn't matter if the size of the diameter of the circle increased or decreased. The ratio remained the same. Even if you measure the diameter around a bouncy ball or around the planet Earth, the circumference is always a bit more than 3 times larger than the diameter. This ratio of circumference to diameter represents a constant value called pi. It is one of the most fascinating values in mathematics.

In this lesson, you will learn more about the importance of pi ( $\pi$ ) and why it has fascinated and puzzled mathematicians for over 4000 years.

You will need a compass and ruler to complete the activities in this lesson.



### Explore Online

Looking for more practice or just want to play some fun games?

If you have internet access, go to the Math 7 website at:

<http://www.openschool.bc.ca/courses/math/math7/mod3.html>

Look for *Lesson 3.3C: Circumference of a Circle* and check out some of the links!



## Warm-up

To get ready for this lesson, let's do a quick review of the parts of the circle. Label the following diagram by filling in the blanks.

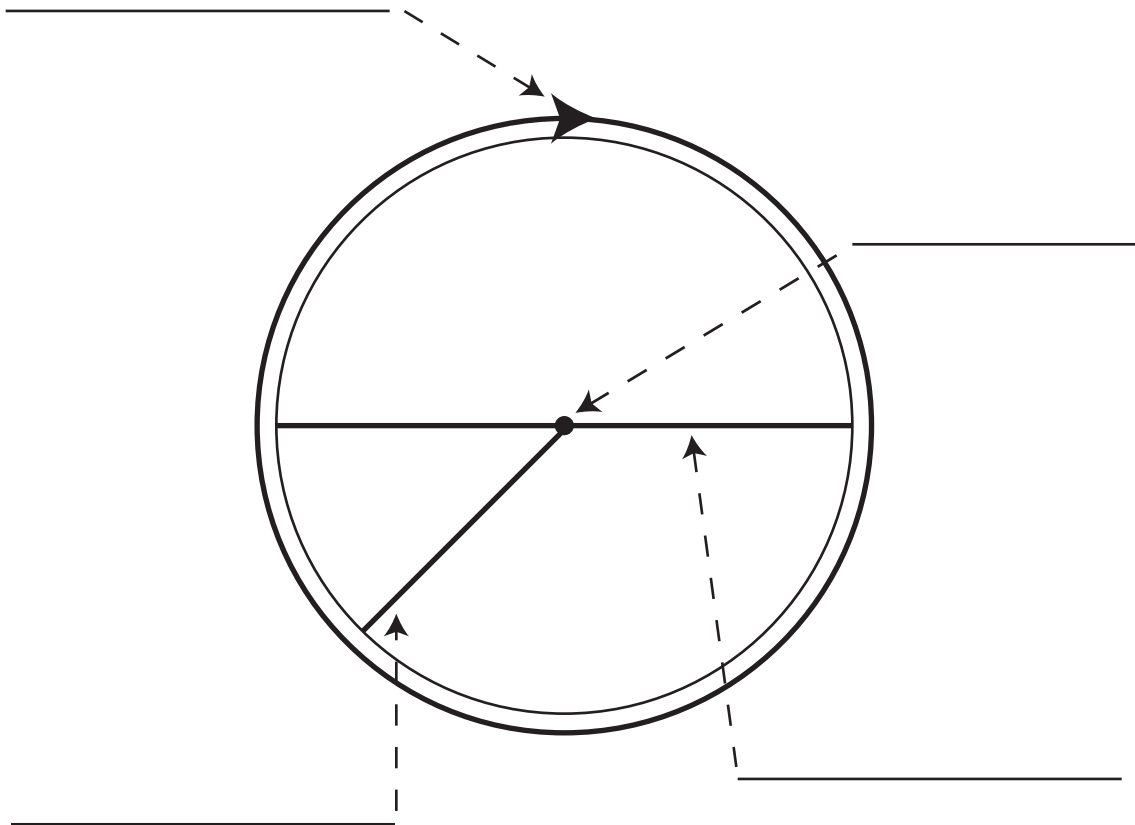

Turn to the Answer Key at the end of the Module and mark your answers.



## Explore

### A Piece of the Pi

The value of  $\pi$  has fascinated mathematicians for over 4000 years. Many people have tried to find the exact value of  $\pi$ .

$$\pi \text{ is } \approx 3.14$$

TIMELINE OF PI	
1900 BC	A Babylonian tablet (ca. 1900–1680 BC) indicates a value of 3.125 for $\pi$ .
1650 BC	An Egyptian papyrus (1650 BC) shows evidence of calculating $\pi$ as 3.1605.
900 BC	Astronomer Yajnavalkya from India calculates $\pi$ correct to two decimal places.
250 BC	Mathematician Archimedes of Syracuse, Greece, works out the value of $\pi$ to 4 decimal places – 3.1416.
450 AD	Chinese mathematician, Zu Chongzhi, calculates $\pi$ to 9 decimal places (3.141592653).
1430 AD	Persian mathematician, Jamshid al-Kashi, finds $\pi$ to 16 decimal places.
1610 AD	Dutch mathematician, Leudolph van Ceulen, spends much of his life calculating $\pi$ up to 35 decimal places. The numbers 2, 8, 8 are engraved on his tombstone, which are the thirty-third, thirty-fourth, and thirty-fifth decimal places of $\pi$ .
1706 AD	Welsh mathematician, William Jones, is the first person to use the Greek letter $\pi$ .
1873 AD	English mathematician, William Shanks, takes 15 years to calculate $\pi$ to 707 digits. Due to a calculation error, he is only correct up to the first 527 places.
1949 AD	Hungarian mathematician, John von Neumann, uses the ENIAC computer to compute $\pi$ to 2037 digits, which takes 70 hours. The ENIAC was America's first electronic computer. It was so large that it weighed 27 tonnes, and was the size of an entire room.
1961 AD	American mathematicians, John Wrench and Daniel Shanks, find $\pi$ to 100,000 digits.

Thinking Space

1989 AD	The Chudnovsky brothers, born in Kiev, Ukraine, find $\pi$ up to the one-billionth digit on their home built super-computer.
1997 AD	Japanese mathematicians, Kanada and Takahashi, calculate $\pi$ to the 51.5 billion digit in just over 29 hours, at an average rate of nearly 500,000 digits per second!

Whew! You can see that pi has had a long and fascinating history. Can you guess why many mathematicians call March 14  $\pi$  day?

You guessed it – 3.14 (3 – third month, 14 – fourteenth day)

### Calculate the Circumference given the Diameter of a Circle

The circumference of a circle is always 3.14 times larger than the diameter. This is true for any circle. If you know what the diameter of a circle is, can you figure out what the circumference will be?

In your thinking space, see if you can find the circumference of a circle with a diameter of 3 cm.

To find the circumference, you multiply the diameter by  $\pi$ . Can you write a formula for this equation?

The formula is written:

$$C = \pi d$$

#### Example:

Find the circumference of a circle with a diameter of 3.0 cm.

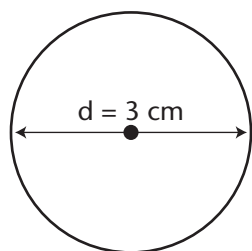

Step 1: Write down the formula, and include what you know.

$$C = \pi \times d$$

$$C = \pi \times 3.0$$

Step 2: You can press the  $\pi$  button on your calculator and multiply by 3, or

$$\text{You can multiply } 3.14 \times 3 = 9.42$$

Step 3: Write down the circumference to one decimal place (because the diameter is given to one decimal place) and include units.

$$C = 9.4 \text{ cm}$$

### Calculate the Circumference of a Circle given the Radius

The radius is the length of a line segment from the centre of the circle to the circumference of a circle. All radii within a circle are equal.

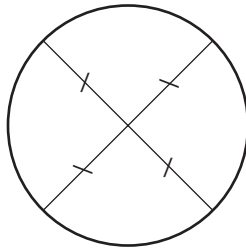

If the diameter of a circle is 4 cm, what is the radius equal to?

Remember, the radius is always half the diameter.

$$\text{Radius} = \text{diameter} \div 2$$

Can you write a formula to find the circumference of a circle given the radius instead of the diameter? *Remember:*  $C = \pi \times d$

If diameter = radius ( $r$ )  $\times$  2, then the formula must be:

$$\text{Circumference} = 2 \times \text{radius} \times \pi$$



The formula is written as:

$$C = 2\pi r$$

### Example:

Find the circumference of a circle with a radius of 4.0 cm.

Step 1: Write down the formula and include what you know.

$$C = 2 \times \pi \times r$$

$$C = 2 \times \pi \times 4$$

Step 2: You can press the  $\pi$  button on your calculator and multiply by 2 and then multiply by 4, or  
You can multiply  $2 \times 3.14 \times 4 = 25.1$

Step 3: Write down the circumference to one decimal place (because the diameter is given to one decimal place) and include units.

$$C = 25.1 \text{ cm}$$

The work on your page should look like this:

$$C = 2\pi r$$

$$C = 2 \times \pi \times 4$$

$$C = 25.1 \text{ cm}$$

### Calculate the Diameter given the Circumference of a Circle

The ratio of circumference to diameter is 3.14:1. You can find the circumference of any circle by multiplying the diameter by 3.14. If you know what the circumference of a circle is, can you figure out what the diameter will be? In your thinking space, see if you can find the diameter of a circle with a circumference of 9.0 cm.

To find the diameter, you divide the circumference by  $\pi$ . Can you write a formula for this equation?

Thinking Space



The formula is written:

$$d = \frac{C}{\pi}$$

**Example:**

Find the diameter of a circle with a circumference of 9.0 cm.

Step 1: Write down the formula and include what you know.

$$d = \frac{C}{\pi}$$

$$d = \frac{9.0}{\pi}$$

Step 2: You can punch 9.0 into your calculator, then push the divide button followed by the  $\pi$  button on your calculator, or  
You can divide 9 by 3.14 = 2.866.

Step 3: Write down the diameter to one decimal place (because the circumference is given to one decimal place) and include units.  
 $d = 2.9$  cm

The work on your page should look like this:

$$d = \frac{C}{\pi}$$

$$d = \frac{9.0}{\pi}$$

$$d = 2.9 \text{ cm}$$

Thinking Space



## Practice

1. Measure the diameter of the following circles, and then calculate the circumference.

a.

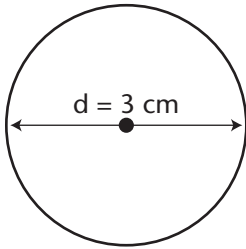

b.

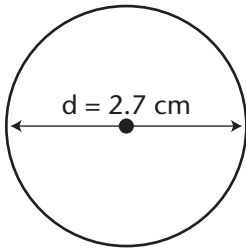

2. Determine the diameter of each circle with a given radius:

a.  $r = 3.0$  cm

b.  $r = 4.6$  m

c.  $r = 1.9$  mm



3. Determine the radius of each circle with a given diameter:

a.  $d = 4.0$  m

b.  $d = 12.4$  cm

c.  $d = 9.2$  mm

4. Determine the circumference of a circle with each diameter:

a.  $d = 10.0$  cm

b.  $d = 6.7$  m

5. Determine the circumference of a circle with each radius:

a.  $r = 5.0$  cm

b.  $r = 2.3$  m

c.  $r = 7.0$  mm

6. What is the radius of a circle with a circumference of 31.4 cm?

7. What is the diameter of a circle with a circumference of 24.0 cm?

8. Fill in the following table:

RADIUS	DIAMETER	CIRCUMFERENCE
5.0 cm		
		28.3 cm
	8.0 m	
	4.6 mm	
1.6 cm		10.0 cm
	7.2 m	

9. The radius of a pizza is 12 cm. Determine the circumference of the pizza.



Turn to the Answer Key at the end of the Module and mark your answers.



## Lesson 3.3D: Area of a Circle

### Student Inquiry



This activity will help you get ready for, learn, and review the information in the upcoming lesson.

When you turn this page over, you will find a chart containing the inquiry outcomes for this lesson. You may be able to answer some of these questions already! Start by writing down your thoughts before the lesson.

When you finish the lesson, answer each question and give an example.

Student Inquiries	BEFORE THE LESSON What I already know about this question:	AFTER THE LESSON What I thought at the end: My final answer, and examples:
Can I solve problems involving circles?		answer  example
How do I estimate the area of a circle without using a formula?		answer  example
What formula do I use to find the area of a circle?		answer  example
How can I solve a problem involving the area of triangles, parallelograms, and/or circles?		answer  example

## Lesson 3.3D: Area of a Circle

### Introduction

If you take a string and make a square shape, the area inside the square will be smaller than if you made a circle with the same string. This is why igloos are made in the shape of a dome. It takes the least amount of snow to get the most amount of room, so heat will not be wasted.

In this lesson, you will learn how to find the area of a circle by dividing it into triangles. Think of a round pizza that can be cut into triangular pieces of pizza. You know how to find the area of a triangle, so you will be able to estimate the area of a circle!

You will need graph paper, ruler, pencil, calculator, and compass to complete the activities in this lesson.

Thinking Space





## Warm-up

Area is the amount of surface within a shape. You know that the area inside a triangle is  $\text{base} \times \text{height} \div 2$ . If a triangle has a base of 3 cm and a height of 10 cm, you know that the area is  $3 \times 10 \div 2$ , which equals  $15 \text{ cm}^2$ .

You also know that the area inside a parallelogram is  $\text{base} \times \text{height}$ . If the base of a parallelogram is 6.2 cm and the height is 4.9 cm, then the area is  $6.2 \text{ cm} \times 4.9 \text{ cm}$ . The area is  $30.4 \text{ cm}^2$ .

A circle is round and doesn't have a base or height like the triangle or parallelogram. How can you determine the area of a circle without these measurements?

Let's find out how to determine the area of a circle.

Thinking Space







## Explore

### Estimating the Area of a Circle

Thinking Space

In the space below, brainstorm some possible ways to estimate the area of a circle.

Try these ways to estimate the area of a circle:

**Method 1.** You can draw a circle on graph paper and count the squares.

- Step 1: Draw a line segment 3 units long on graph paper. This will be the radius of your circle.
- Step 2: Place your compass point on the beginning point of the line segment and your pencil on the end point of the line segment.
- Step 3: Draw a circle with your compass.
- Step 4: Count the whole squares inside the circle.
- Step 5: Combine parts of squares to equal whole numbers and add that number to your whole square count.
- Step 6: The total number of squares inside the circle is the area.

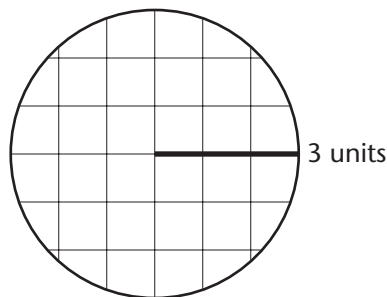

Did you count approximately 28 square units inside the circle?

## Method 2. Estimate the area by dividing a circle into triangles.

A circle is round, so it does not have base and height measurements like the triangle and parallelogram, but there is something you can do to create a base and height. Think of a circle like a pizza pie. If you cut the pizza into 8 slices, you will have 8 triangular pieces of pizza. You can then arrange the pizza slices on a table into a parallelogram. You can do the same thing with a circle. If you divide a circle into triangles and form a parallelogram, you can measure a base and height. By multiplying the base and height, you can *estimate* the area of a circle. Does the area of the circle change when you turn it into a parallelogram?

Let's figure out how to divide a circle into triangles to estimate the area. Follow the steps below on a separate piece of paper.

- Step 1: Draw a line segment on graph paper to be the length of the radius. For example, use a radius of 3 cm.
- Step 2: Adjust your compass so that it is the width of the line segment.
- Step 3: Draw a circle using the line segment as the radius.
- Step 4: Use your scissors to cut out the circle.
- Step 5: Fold your circle in half, then again in half and again in half.
- Step 6: Unfold the circle to find 8 triangular segments.
- Step 7: Cut along the fold lines to get 8 triangles.
- Step 8: Arrange the triangles on graph paper so that it makes a parallelogram shape.
- Step 9: Use your ruler and pencil to outline the base and height of the parallelogram.
- Step 10: Count the squares to measure the base and height.
- Step 11: Estimate the area by multiplying the base x height.
- Step 12: Write down your answer in units.

Thinking Space



**Example:**

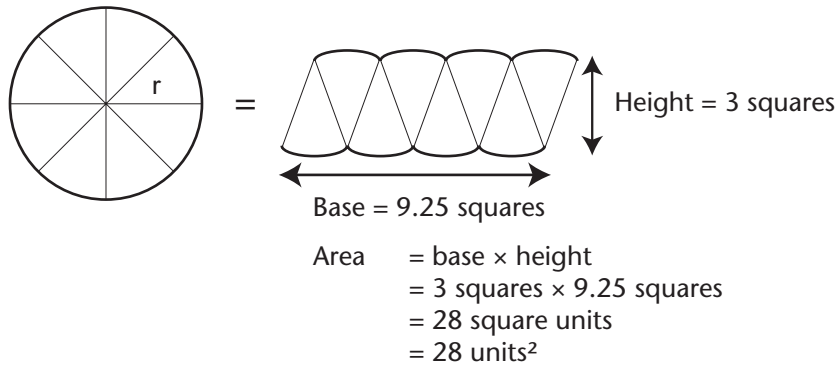

**Using a Formula to Find the Area of a Circle**

You know how to estimate the area of a circle by dividing a circle into triangles to make a parallelogram. By measuring the height and width of the parallelogram, you can determine the area. Look at the parallelogram below. How is the radius of the circle similar to the height of the parallelogram?

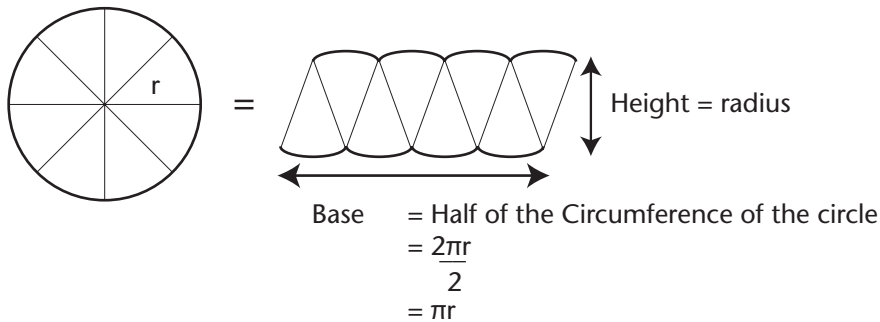

Did you guess that the height and the radius are equal? Yes, it is.

How is the width of the parallelogram similar to the circumference?

The width of the parallelogram is half the length of the circumference. The circumference of a circle is  $2\pi r$  so the width is equal to  $\frac{1}{2} \times 2 \times \pi \times r$ , which is  $\pi \times r$ .

The width is  $\pi r$  and the height is  $r$ . Can you determine the formula to find the area of a circle?

How did you do?

Thinking Space



Let's try together:

Area of a parallelogram = base  $\times$  height =  $\pi \times r \times r$  (or  $r^2$ )

Area of a circle =  $\pi r^2$

Let's practise using the formula to find the area of a circle.

### Example 1:

A circle has a radius of 5.0 cm. Find the area of the circle.

Step 1: Use the formula to find area.

$$\text{Area} = \pi \times r^2$$

$$\text{Area} = 3.14 \times 5^2$$

$$\text{Area} = 3.14 \times 5 \times 5$$

$$\text{Area} = 78.5 \text{ cm}^2$$

Step 2: Write down the area with units.

The area of the circle is  $78.5 \text{ cm}^2$ .

### Example 2:

A circle has a diameter of 8.0 cm. Find the area of a circle.

Step 1: Find the radius of the circle

$$\text{Radius} = \text{diameter} \div 2$$

$$\text{Radius} = 8 \div 2 = 4$$

Step 2: Use the formula to find area.

$$\text{Area} = \pi \times r^2$$

$$\text{Area} = 3.14 \times 4^2$$

$$\text{Area} = 3.14 \times 4 \times 4$$

$$\text{Area} = 50.2 \text{ cm}^2$$

Step 3: Write down the area including units.

The area of the circle is  $50.2 \text{ cm}^2$ .

What if an object has multiple shapes added together? How can I find the area?

Many objects or structures you see in your daily life are often a combination of shapes. Have you noticed that the shape of a hockey rink is a rectangle in the middle with two semi-circles at each end? Or how about the shape of a doghouse? It has a triangular roof and square bottom. You can also find circles within circles, like the shape of a CD. How can you find the area if an object has two shapes? What formula can you use?

To find the area of these shapes, you need to break up the question into parts and then solve.

Here are some examples to show you how to solve a multiple-step problem.

### Example 3:

This hockey rink consists of a rectangle and two semi-circles. The length of the rectangle is 16.0 m and the radius of the semi-circle at each end is 5.0 m. Find the area of the hockey rink.

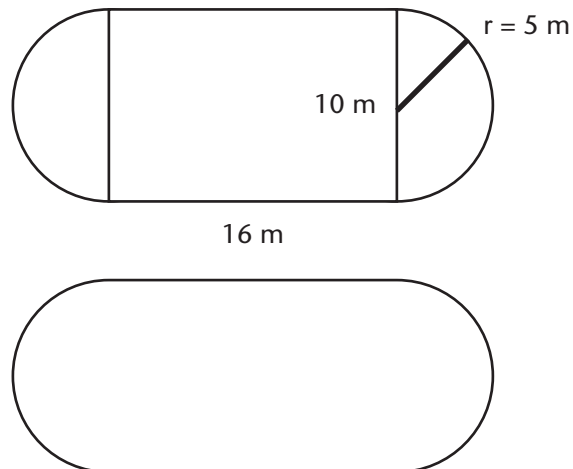

### Thinking Space



Step 1: Understand the problem.

- a. Highlight the clue words:
- “hockey rink consists of a rectangle and two semi-circles.”
  - “length of the rectangle is 16.0 m”
  - “radius of the semi-circle at each end is 5.0 m”
  - “find the area of the hockey rink.”

Determine if measurements are given:

- Length of rectangle = 16 m
- Radius of semi-circle = 5 m

- b. Draw a picture:
- Look at the illustration on the previous page.
- c. Underline the questions:
- You are asked to find the area of the hockey rink. The shape is a rectangle plus two semi-circles.

Step 2: Make a plan.

- a. Make a list of clue words, and how they will help you solve the problem.
- “hockey rink consists of a rectangle and two semi-circles”  
What is a “semi-circle?”  
A semi-circle is half of a circle. You know that two semi-circles equal one circle. Think of it like a pizza that you cut in half. Two halves of a pizza makes a whole pizza. One shape of the hockey rink is a whole circle, and the other shape is a rectangle.
  - “radius of the semi-circle at each end is 5.0 m”  
You are given the radius of the two semi-circles so you can calculate the area.
  - “length of the rectangle is 16.0 m”  
You are given the length of the rectangle but not the width. Is there any other information that can help you find the width? Look at the illustration of the hockey rink. You will see that the radius is equal to half the width of the hockey rink. The radius of the semicircle is  $\frac{1}{2}$  the distance of the width of the rectangle. So, the width of the rectangle equals  $5 \times 2 = 10$ .

- “find the area of the hockey rink”  
Add the area of the circle and rectangle to determine the area of the hockey rink.
- b. Consider units:  
The radius of the semi-circle and the length of the rectangle are both in metres.
- c. Decide on how many parts you need to solve in the problem:  
This is a three-part question:
1. Find the area of the rectangle.
  2. Find the area of the circle.
  3. Add the area of the rectangle and the area of the circle to find the area of the hockey rink.

Step 3: Carry out the plan.

Find the area of the rectangle.

Area = length  $\times$  width

Area =  $10 \times 16$

Area =  $160 \text{ m}^2$

The area of the rectangle equals  $160 \text{ m}^2$ .

Find the area of the circle.

Area =  $\pi r^2$

$A = 3.14 \times 5^2$

$A = 3.14 \times 5 \times 5$

$A = 78.5$

The area of the two semi-circles equal  $78.5 \text{ m}^2$ .

Add the area of the rectangle and the area of the circle to find the area of the hockey rink.

Area = rectangle + two semi-circles

$A = 160 + 78.5$

$A = 238.5 \text{ m}^2$

Step 4: Answer the question asked.

What is the area of the hockey rink?

Answer: The area of the hockey rink is  $238.5 \text{ m}^2$ .



## Practice

1. What is the area of each circle?
  - a.  $r = 2.0$  cm
  
  
  
  
  
  
  
  
  
  
  - b.  $r = 2.3$  m
  
  
  
  
  
  
  
  
  
  
2. What is the area of each circle?
  - a.  $d = 8.0$  m
  
  
  
  
  
  
  
  
  
  
  - b.  $d = 3.8$  cm
  
  
  
  
  
  
  
  
  
  
3. A pumpkin pie has a diameter of 28 cm.
  - a. What is the radius of the pie?
  
  
  
  
  
  
  
  
  
  
  - b. What is the area of the pumpkin pie?
  
  
  
  
  
  
  
  
  
  
  - c. The pumpkin pie is cut into 4 pieces. What is the area of one piece of pie?



4. Hayden is painting a circular mural on the side of a building. He will need to paint two coats of paint. The radius of the mural is 1.5 m. How much area in total will he need to paint?

5. A music CD has an outside diameter of 12 cm and an inside diameter of 2 cm. What is the area of the label that would fit onto the CD?

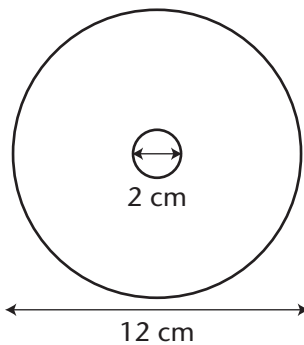

Turn to the Answer Key at the end of the Module and mark your answers.



## Section Summary

### Circle Terminology

Review the vocabulary of circles. You can go back to the table in Lesson 3.3A, or review the glossary.

### How to Draw a Circle

- Step 1. With your pencil and ruler, draw a line segment the length of the radius..
- Step 2. Place the tip of the compass on one point and its pencil on the other point.
- Step 3. Hold the compass so that the distance between the point and the pencil doesn't change.
- Step 4. Draw a circle.

### Radius and Diameter of a Circle

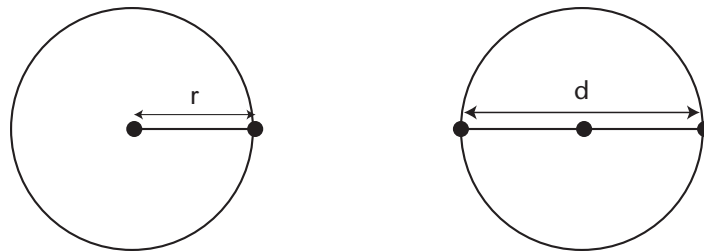

$$\text{Radius} = \text{Diameter} \div 2$$

## Drawing a Circle with a Given Diameter

Step 1. Divide the given diameter by 2 to figure out the radius.

Step 2. Draw a line segment that is the length of the radius.

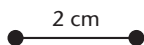

Step 3. Place the tip of the compass on one point of the line segment and its pencil on the other point.

Step 4. Hold the compass so that you won't change the distance between the compass point and the pencil when you draw the circle.

Step 5. Draw a circle.

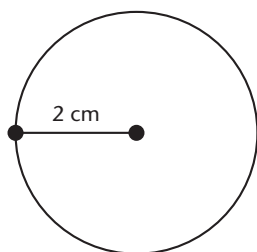

Step 6. Measure the diameter to confirm.

## Formula to Calculate the Circumference of a Circle

$\pi$  is approximately equal to 3.14

Circumference =  $\pi \times$  diameter

$$C = \pi d$$

$$C = 2\pi r$$

## Formula to Calculate the Area of a Circle

$$\text{Area of a circle} = \pi r^2$$

## Section Challenge

Imagine you have a circular mirror hanging on your wall. Accidentally, you knock it off the wall and it falls to the ground and cracks. The wooden rim that holds the mirror in place also breaks. Oh no! What can you do?

You want to replace the mirror, so you get out your measuring tape and measure the diameter of the mirror and the diameter of the rim. Luckily, both the mirror and rim hold together well enough so that you can measure the diameter of both.

When you get to the store and ask for help from the person at the service counter, they ask for the area of both the mirror and rim. The store can replace the mirror and rim if you can provide the area. The person at the counter gives you a pencil, paper, and calculator.

A mirror with a wooden rim has an outside diameter of 30 cm.

The diameter of the mirror is 24 cm. What is the area of the mirror?

What is the area of the rim?

*Your answer should be to one decimal place and include units.*

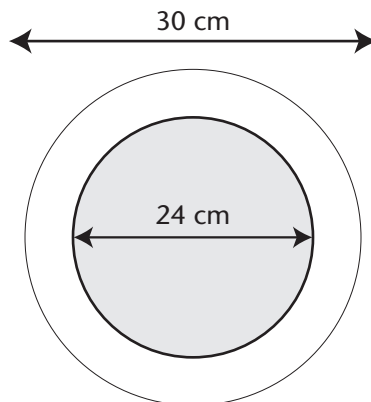



# Module 3 Templates

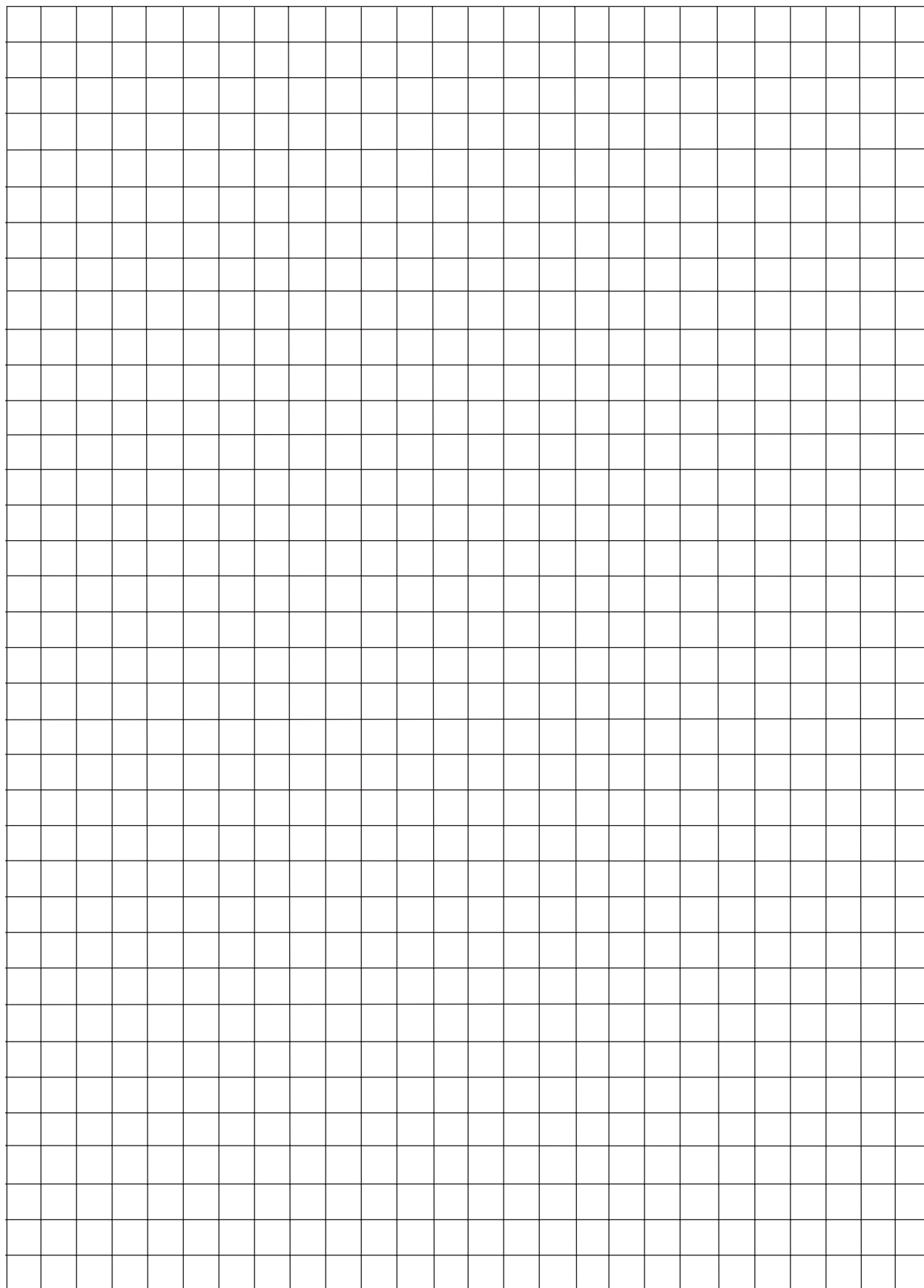

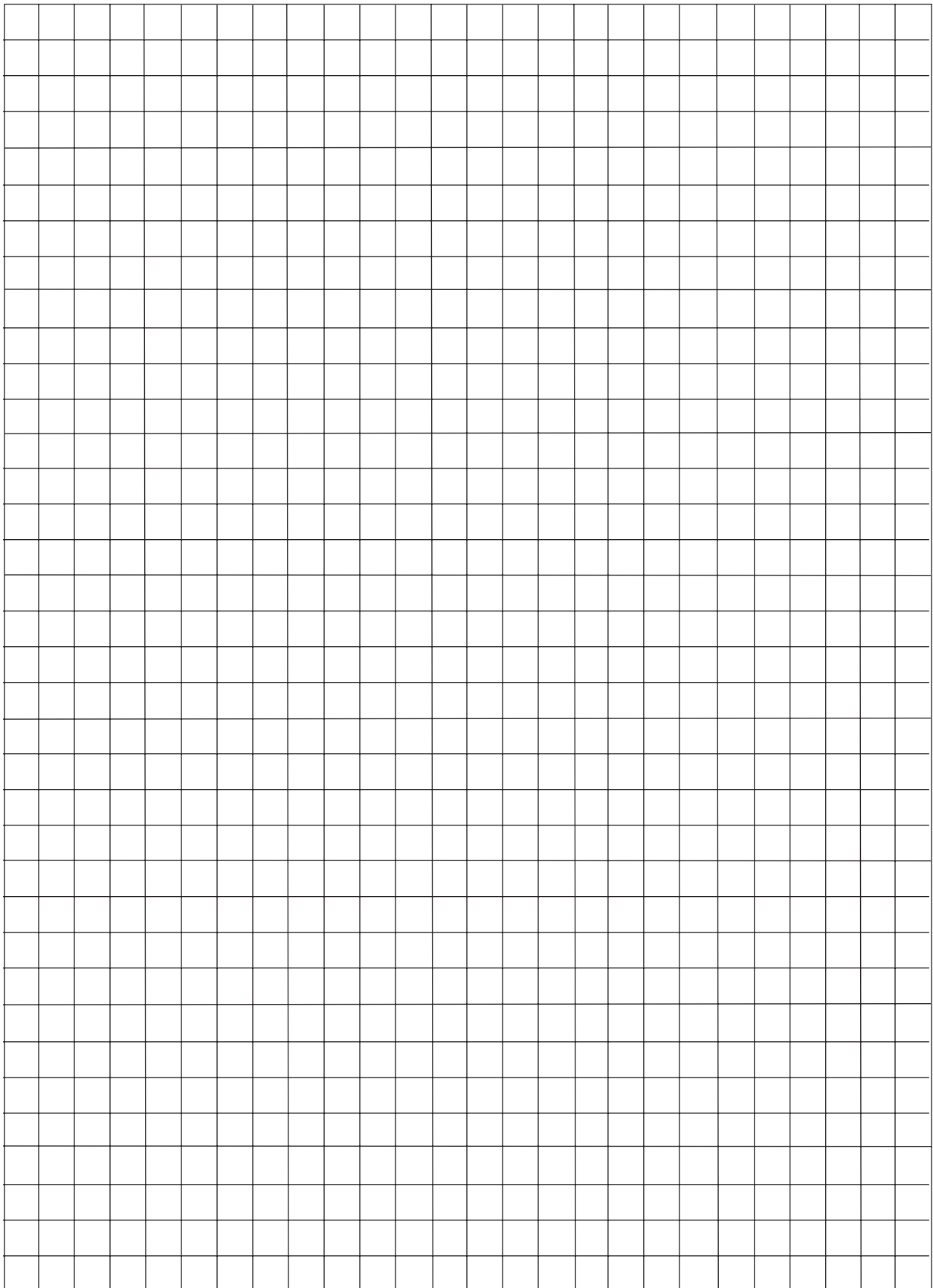



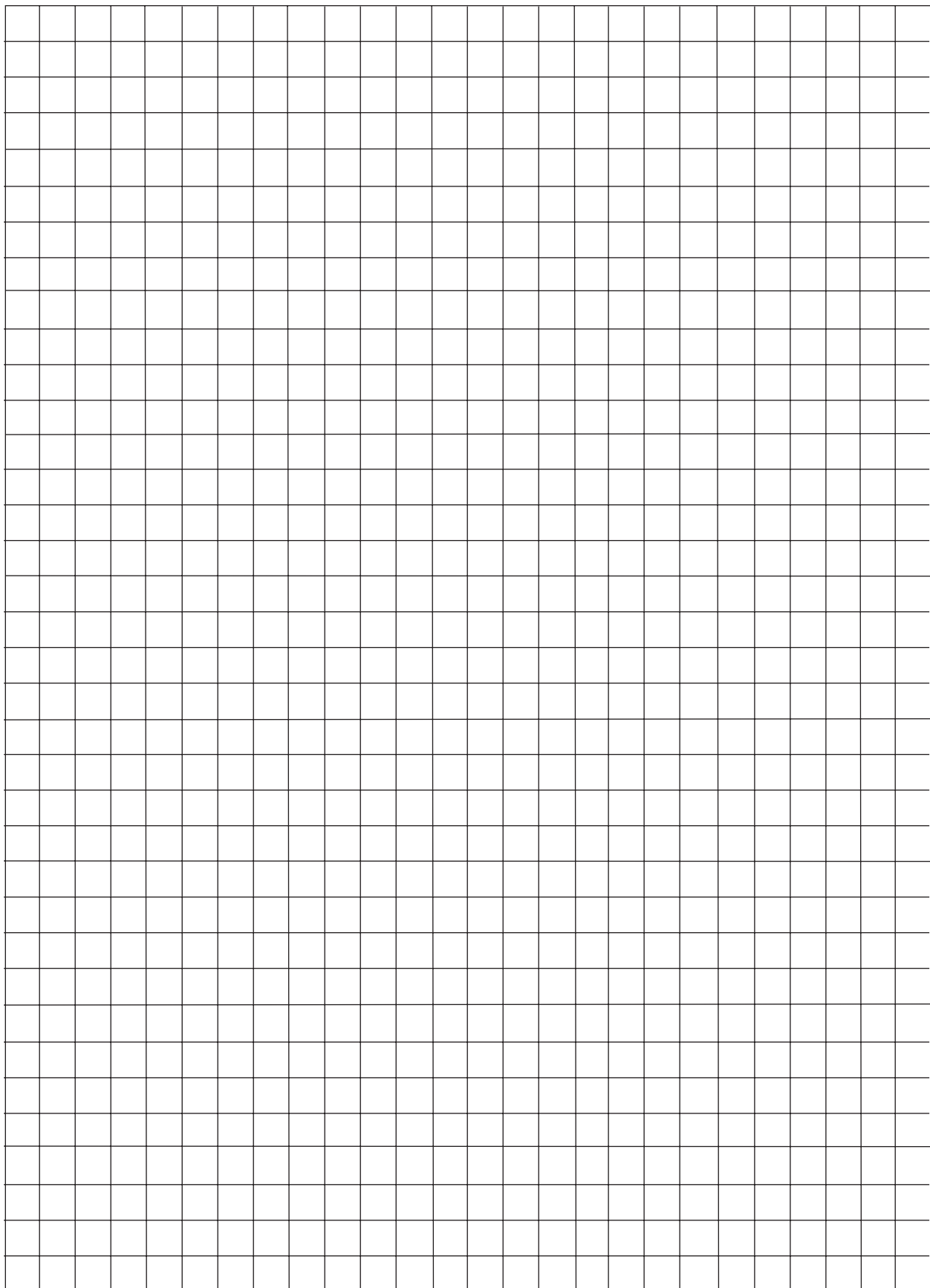

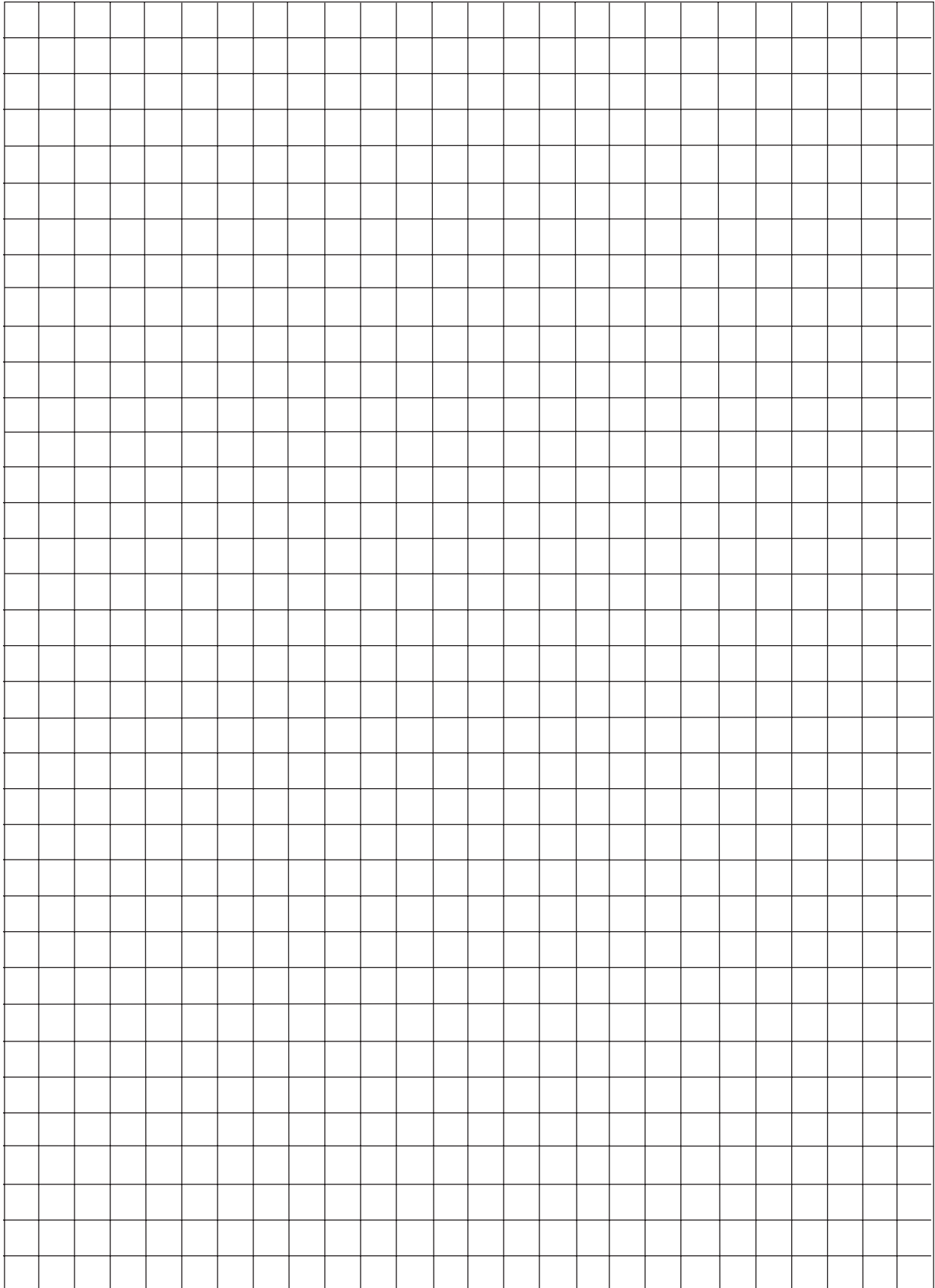

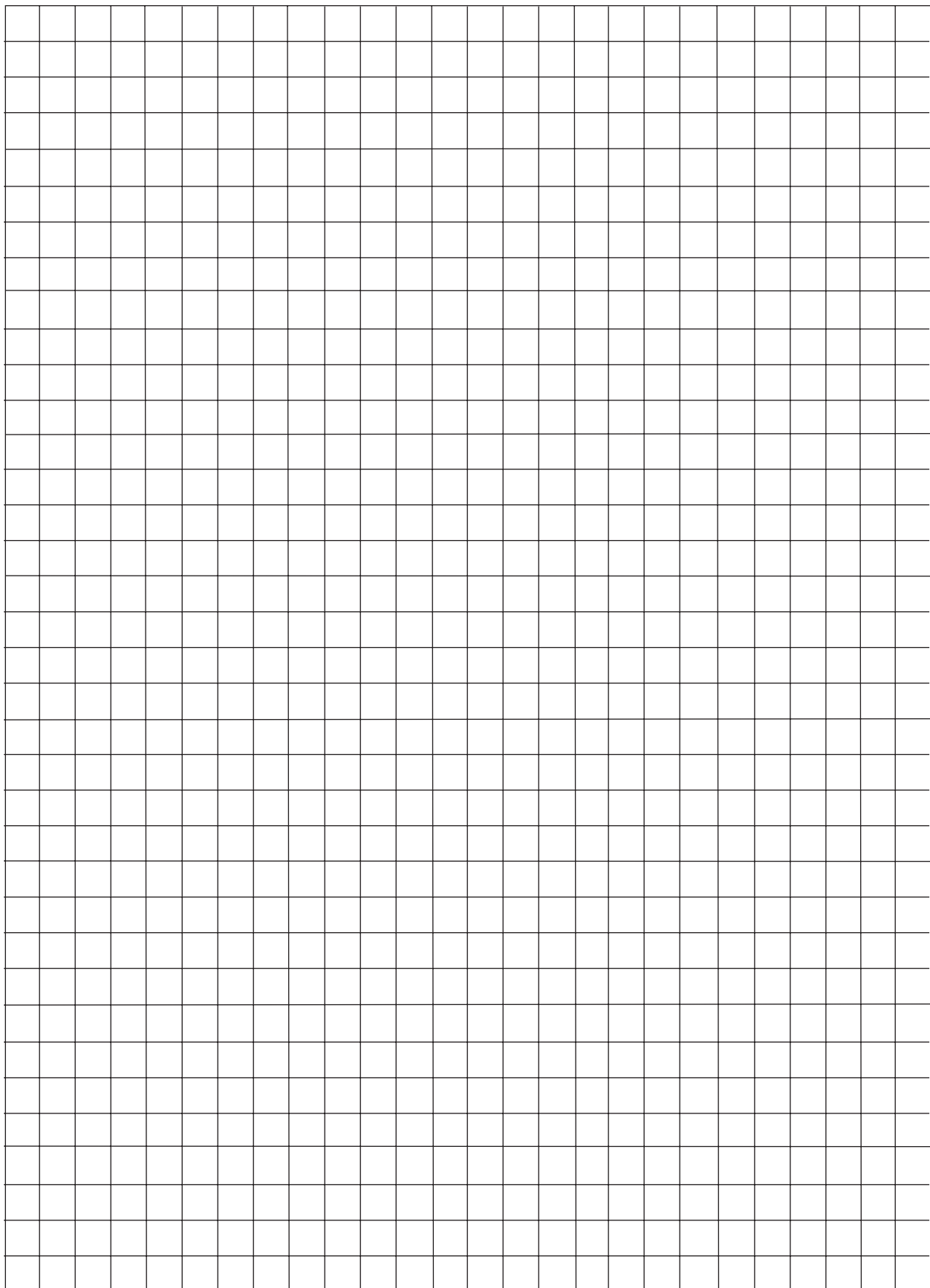

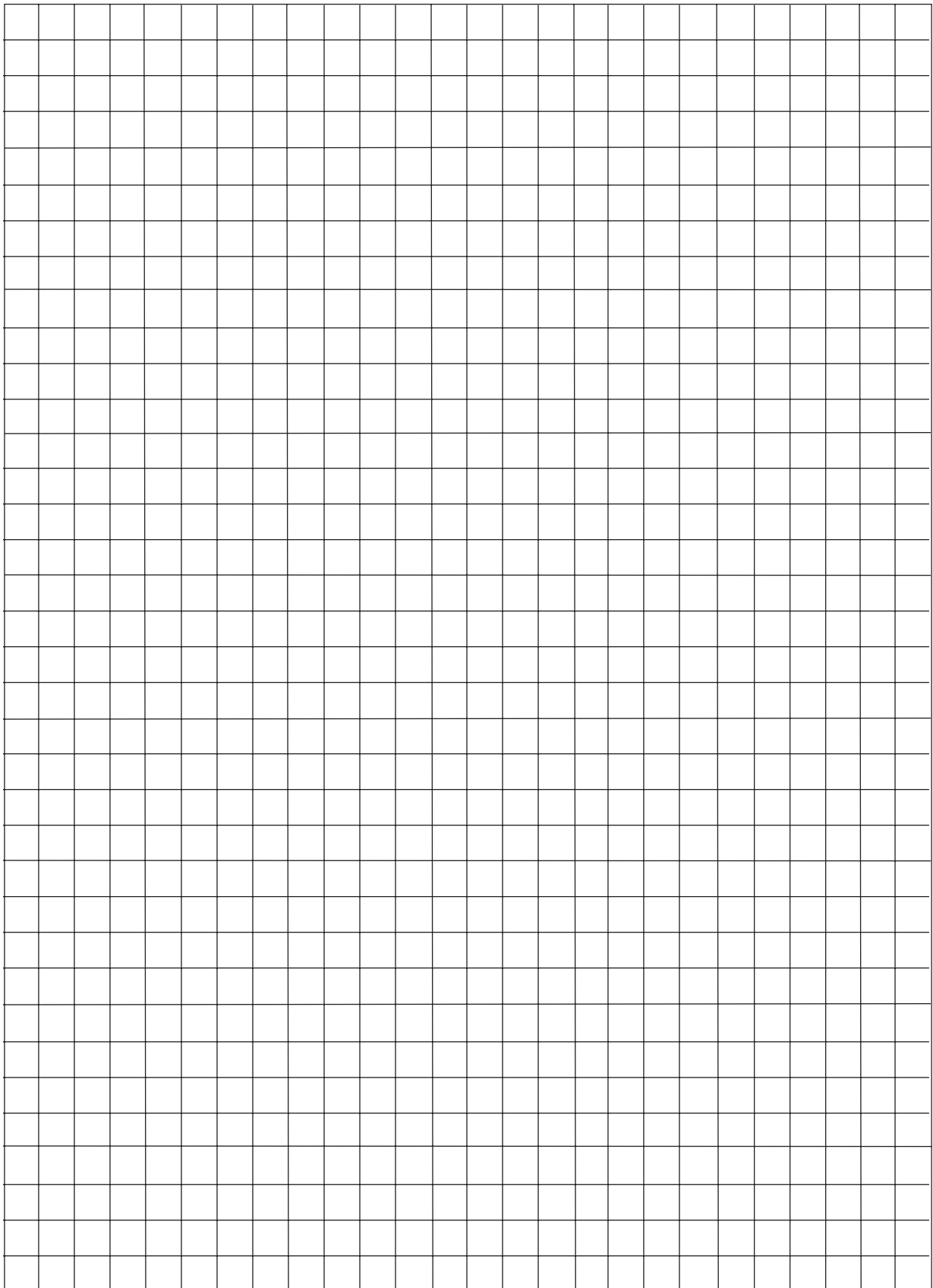

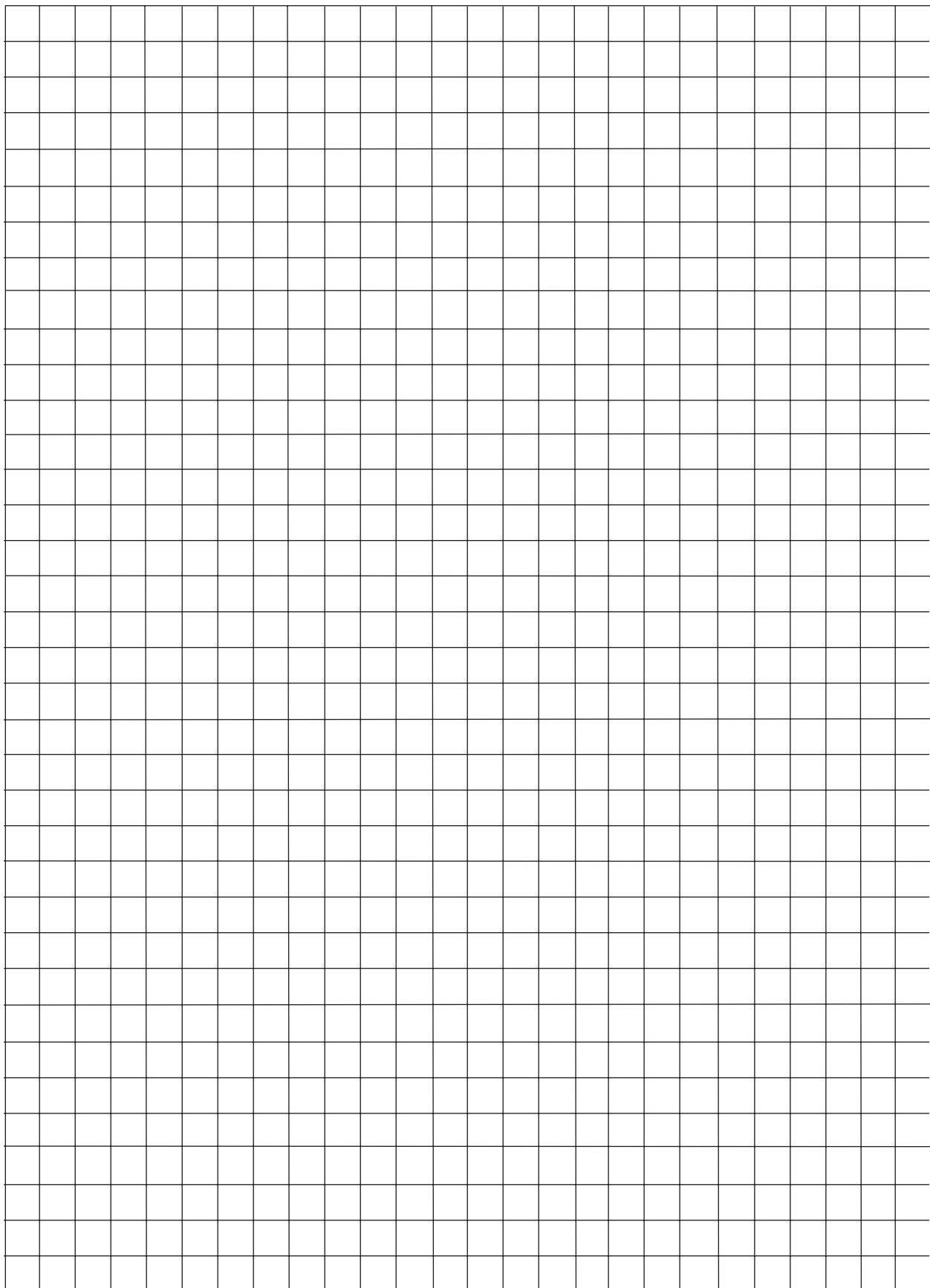

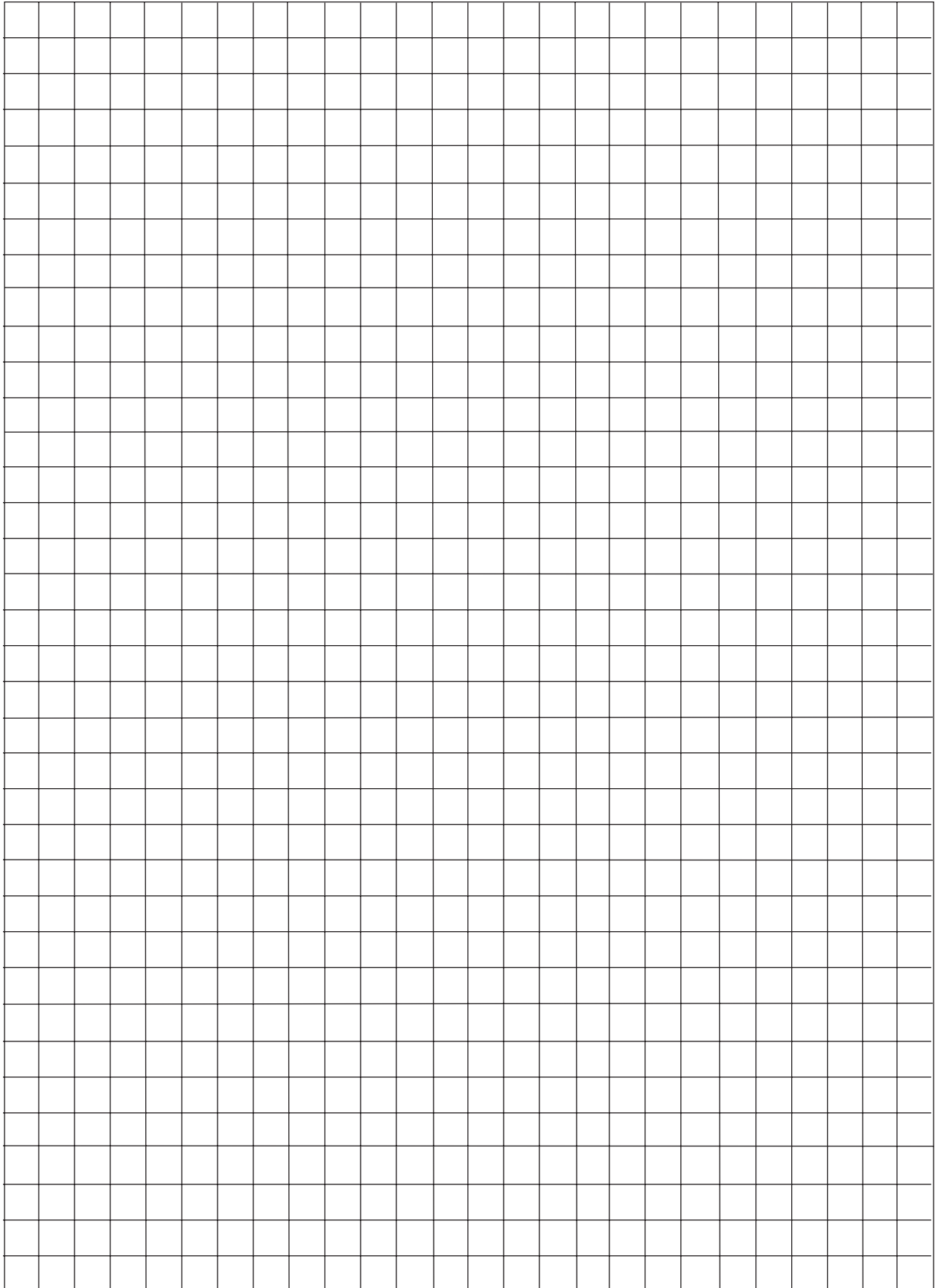

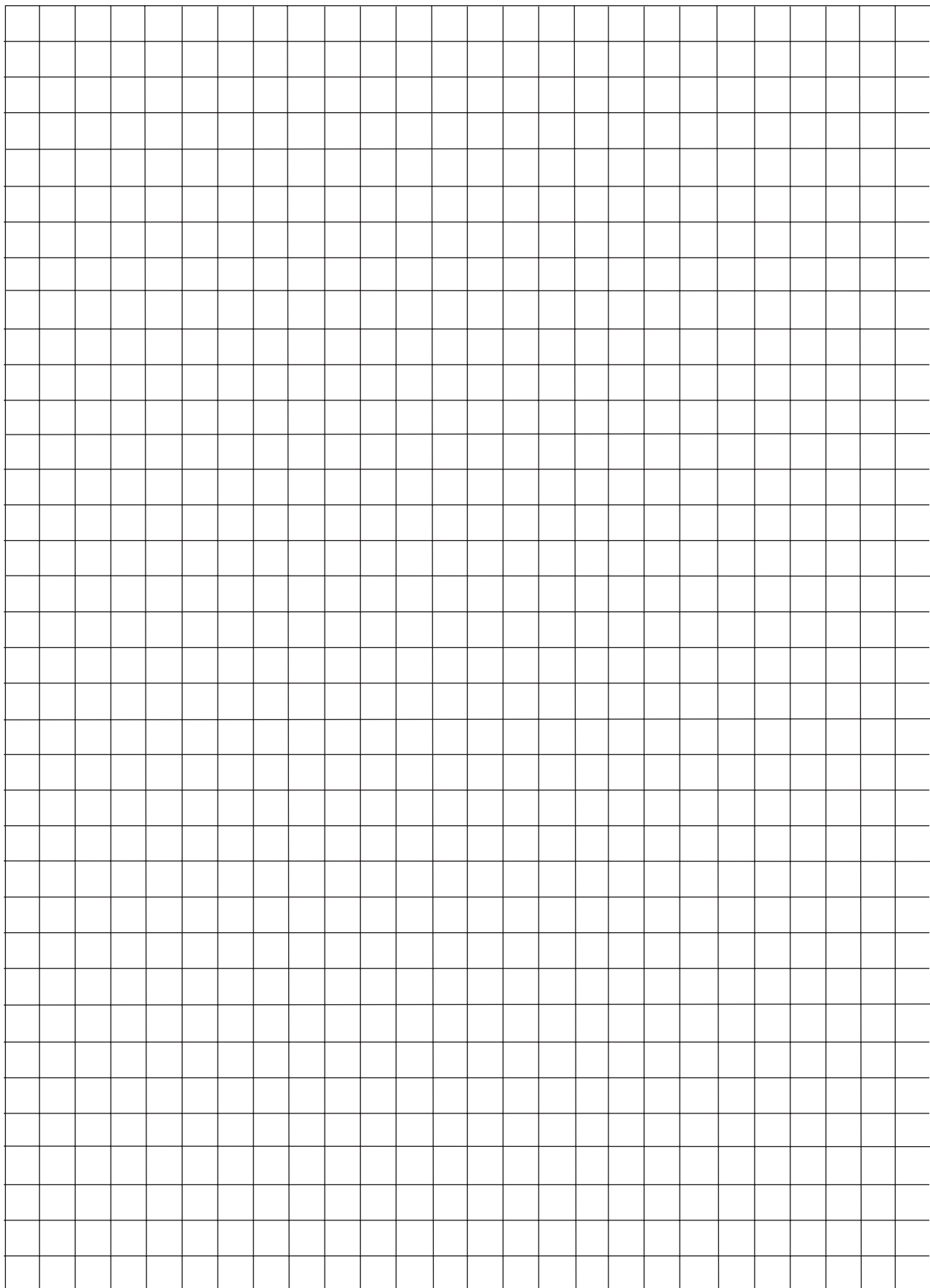

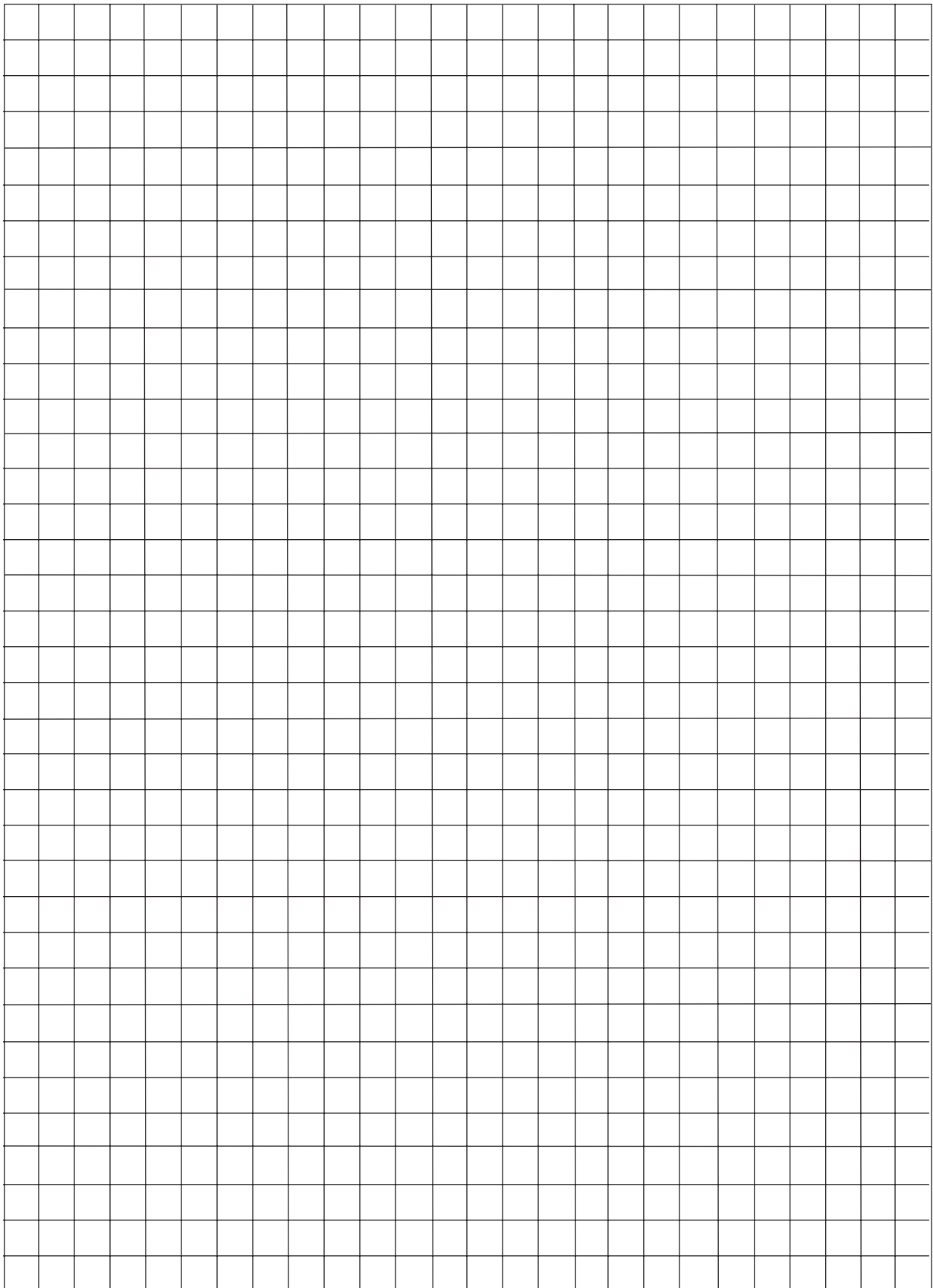



## Answer Key Table of Contents

Pretest 3.1	241
Lesson 3.1A Warm-up	242
Lesson 3.1A Practice 1	243
Lesson 3.1A Practice 2	244
Lesson 3.1B Practice	244
Lesson 3.1C Practice	245
Lesson 3.1D Practice	246
Lesson 3.1E Practice	248
Section Challenge 3.1	249
Pretest 3.2	250
Lesson 3.2A Practice	251
Lesson 3.2B Practice	253
Lesson 3.2C Practice	253
Lesson 3.2D Practice	255
Section Challenge 3.2	256
Pretest 3.3	256
Lesson 3.3A Practice	258
Lesson 3.3B Warm-up	260
Lesson 3.3C Warm-up	261
Lesson 3.3C Practice	261
Lesson 3.3D Practice	263
Section Challenge 3.3	263



### Answer to Pretest 3.1

1. Parallel: A, C  
Perpendicular: B, D
  
2. a. DRAWING: Line segment = 4 cm, angle =  $45^\circ$   
b. DRAWING: Line segment = 3 cm, angle =  $120^\circ$   
c. DRAWING: Line segment = 2.5 cm, angle =  $90^\circ$
  
3. Any three examples, such as streets and avenues, the corners of a picture frame, the corner of the floor and the wall, etc.
  
4. Any three examples, such as rails on a train track, rails of a ladder, the sides of a ruler, etc.
  
5. a. compass  
b. perpendicular bisector  
c. T  
d. protractor  
e. angle bisector
  
6. a. DRAWING: Perpendicular bisector is at 36.5 mm  
b. DRAWING: Perpendicular bisector is at 7 cm  
c. DRAWING: Perpendicular bisector is at 5.5 cm
  
7. a. DRAWING: Angle =  $130^\circ$  with angle bisector at  $65^\circ$   
b. DRAWING: Angle =  $70^\circ$  with angle bisector at  $35^\circ$

8.

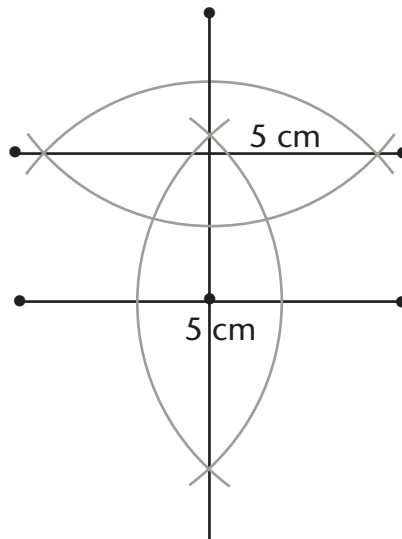

9.

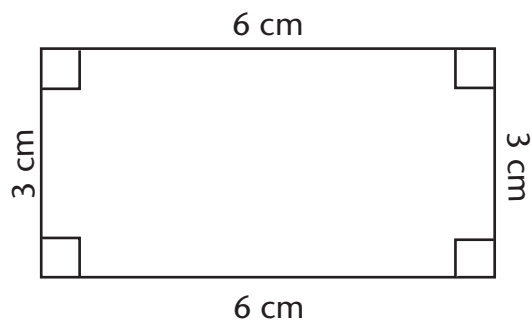

### Answer to Lesson 3.1A Warm-up

1. meet
2. degree
3. parallel
4.  $^{\circ}$
5. 3 o'clock
6. perpendicular

7. right
8. acute
9. obtuse
10. protractor
11. zero
12. a. greater than
  - b. right
  - c. less than
  - d. right
  - e. less than
  - f. greater than

### Answer to Lesson 3.1A Practice 1

1. a.  $30^\circ$ 
  - b.  $65^\circ$
  - c.  $160^\circ$
  - d.  $15^\circ$
2. a.  $\angle A = \underline{45^\circ}$ 
  - b.  $\angle B = \underline{10^\circ}$
  - c.  $\angle C = \underline{95^\circ}$
  - d.  $\angle D = \underline{77^\circ}$
  - e.  $\angle E = \underline{150^\circ}$

## Answer to Lesson 3.1A Practice 2

1. Parallel: A, C

Perpendicular: B, D

2. Right angles: A, C

3. a.

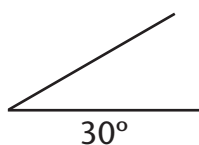

b.

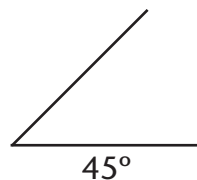

c.

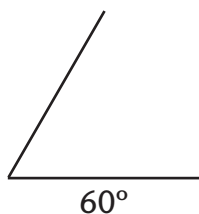

d.

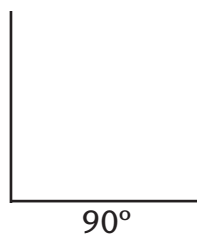

e.



4. Any three examples, such as streets and avenues, the corners of a picture frame, the corner of the floor and the wall, etc.

5. Any three examples, such as rails on a train track, rails of a ladder, the sides of a ruler, etc.

## Answer to Lesson 3.1B Practice

1. a. DRAWING: Flower w/ petals, drawn using compass

b. DRAWING: 30, 45, and 60 degree angles, drawn using only triangles

c. DRAWING: Star

2. Answers will vary.
3. Answers will vary.
4.
  - a. compass
  - b. perpendicular bisector
  - c. T
  - d. protractor
  - e. triangle
  - f. ruler or straight edge
  - g. intersection point
  - h. angle bisector

### Answer to Lesson 3.1C Practice

1. Perpendicular lines meet at a  $90^\circ$  angle.
2.  $\perp$
3. A perpendicular bisector is a line that intersects a line segment at 90 degrees and divides it into two equal lengths.
4.
  - a. DRAWING: Perpendicular bisector is at 3.5 cm
  - b. DRAWING: Perpendicular bisector is at 5 cm
  - c. DRAWING: Perpendicular bisector is at 8.5 cm
5. Either or both of these answers is correct.
  1. Draw a point on the perpendicular bisector. This point should be the same distance from each end of the original line segment.
  2. Measure the line segment with your ruler. The perpendicular bisector should divide the line in half. Use your protractor to measure the angle between the perpendicular bisector and line segment. It should equal  $90^\circ$ .

6.

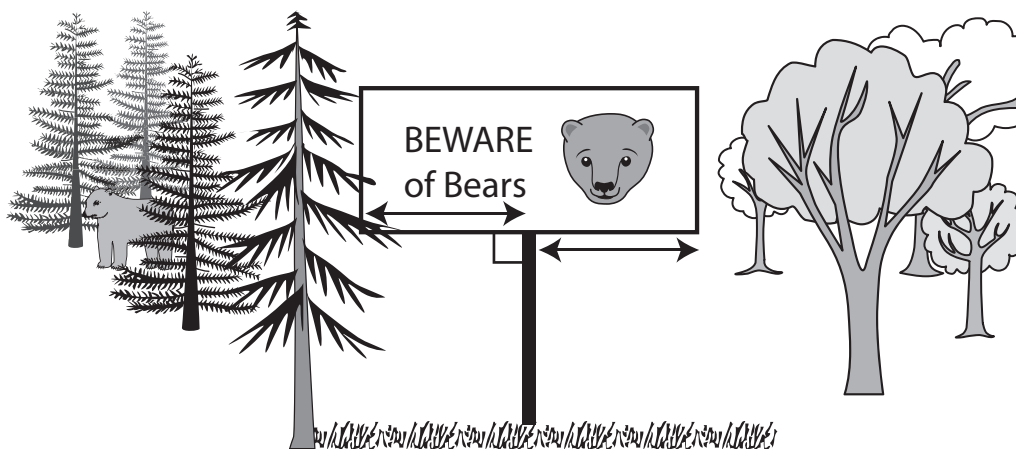

7. Meet at the Zebra exhibit.

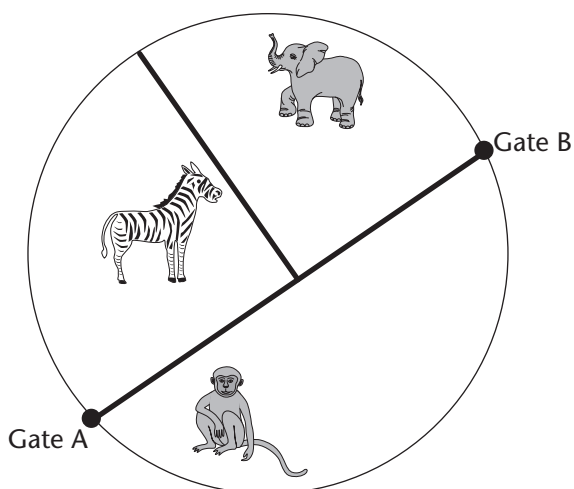

### Answer to Lesson 3.1D Practice

1. a. DRAWING: Angle bisector is at 45 degrees
- b. DRAWING: Angle bisector is at 15 degrees
- c. DRAWING: Angle bisector is at 30 degrees
- d. DRAWING: Angle bisector is at 25 degrees
- e. DRAWING: Angle bisector is at 60 degrees



2.

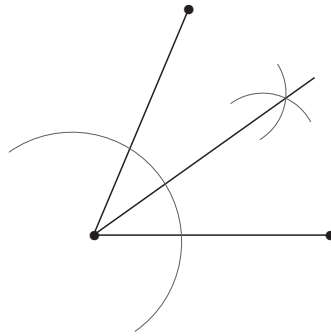

3. a.

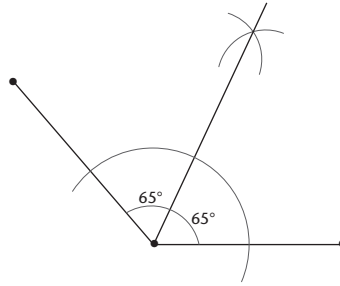

b.

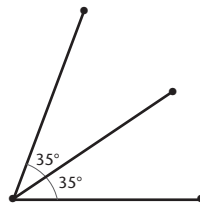

4.

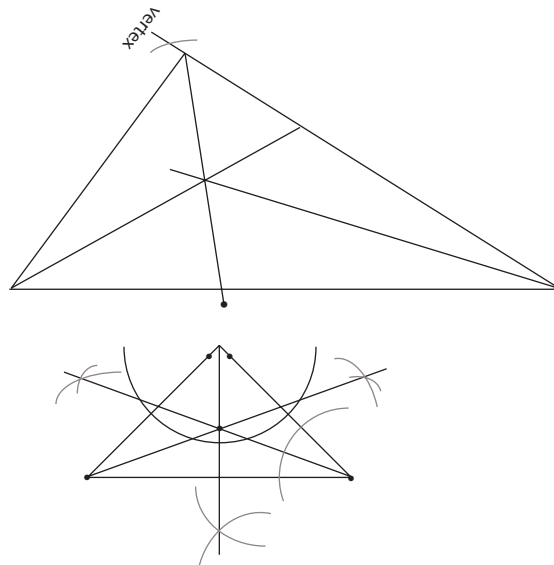

## Answer to Lesson 3.1E Practice

1. Parallel: C, D

2.

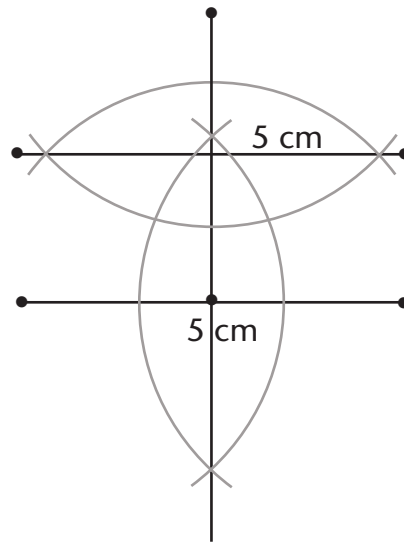

3.

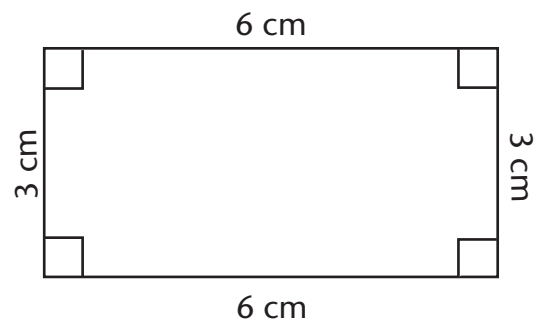

4.

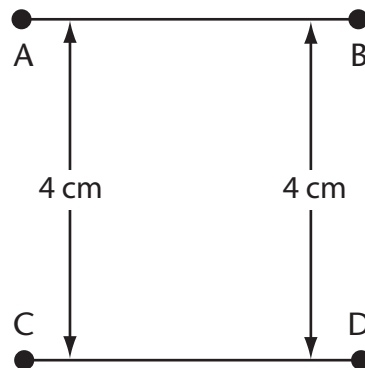

### Answer to Section Challenge 3.1

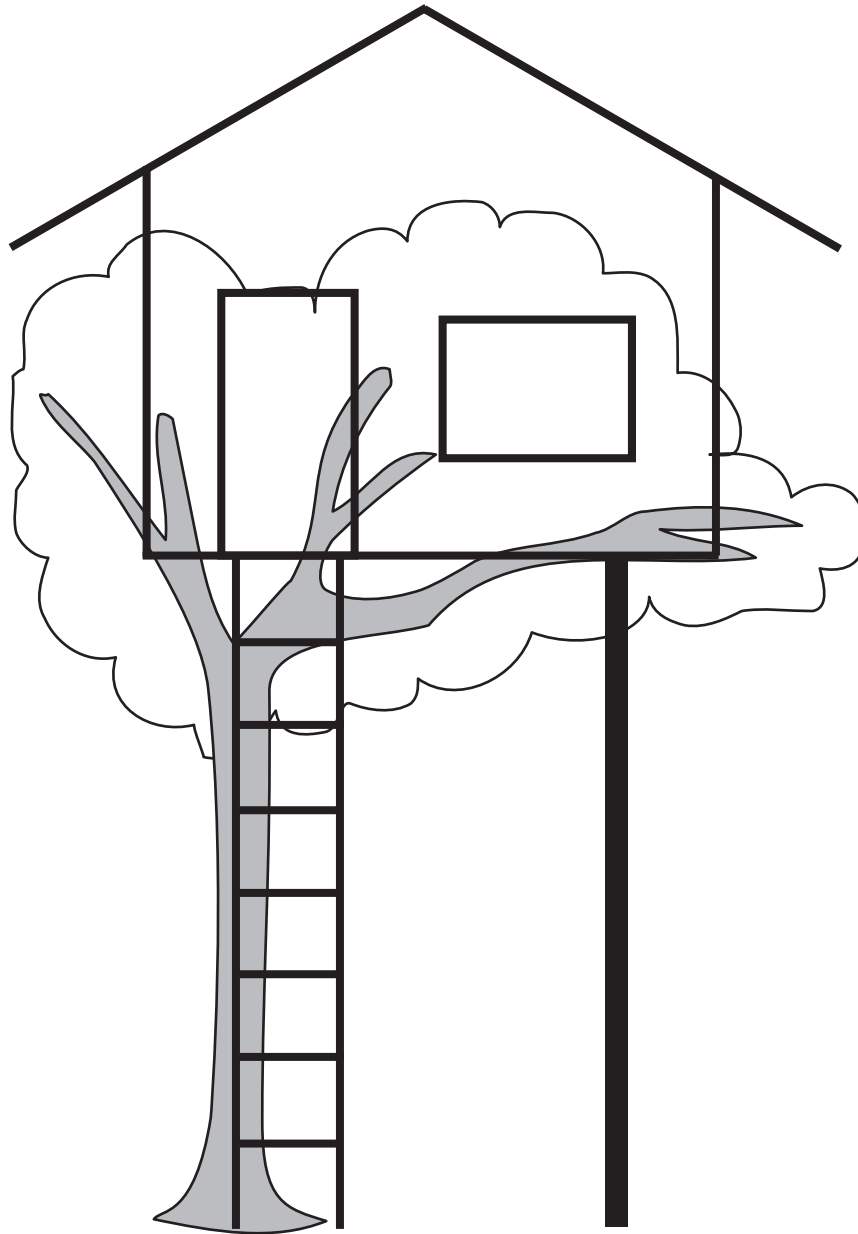

## Answer to Pretest 3.2

1.

- |   |   |       |
|---|---|-------|
| d | distance between Vancouver and Kamloops | a. mm |
| b | your own height                         | b. cm |
| a | length of a spider                      | c. m  |
| c | height of your closet                   | d. km |

2. a.  $3 \text{ m}^2$

b.  $5 \text{ m}^3$

c.  $1 \text{ cm}^2$

d. 2 mm

3. a. 1

b. 1

c. 100

d. 1000

4.

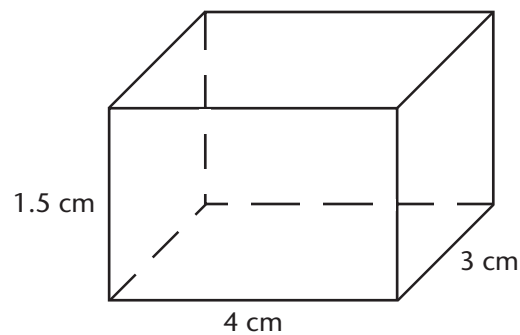

$$V = 18 \text{ cm}^3$$

5.  $12 \text{ m}^2$

6.

BASE	HEIGHT	AREA
125 m	25 m	<b>3125 m<sup>2</sup></b>
36 cm	18 cm	<b>648 cm<sup>2</sup></b>
10.2 m	8.4 m	<b>85.68 m<sup>2</sup></b>
0.25 m	4.93 cm	<b>123.3 cm<sup>2</sup></b>
7 cm	<b>7 cm</b>	49 cm <sup>2</sup>
<b>2 m</b>	3.6 m	7.2 m <sup>2</sup>

7. Robyn can plant 147 daffodils in her garden.

### Answer to Lesson 3.2A Practice

1.

- |   |  |                  |
|---|--|------------------|
| c | used to measure the length of your living room                               | a. ruler         |
| d | used to measure the length around a garbage can                              | b. metre stick   |
| e | used to measure the length around a park                                     | c. tape measure  |
| f | used to measure the angle between the hands of a clock pointing at 3 o'clock | d. rope or chain |
| b | used to measure the height of your Science Fair backboard                    | e. trundle wheel |
| a | used to measure the length of a line segment                                 | f. protractor    |

- 2.
- |   |  |       |
|---|--|-------|
| d | distance between Vancouver and Calgary | a. mm |
| b | your own height                        | b. cm |
| a | length of a ladybug                    | c. m  |
| c | height of your closet                  | d. km |

- 3.
- a.  $2 \text{ m}^2$
  - b.  $5 \text{ m}^3$
  - c.  $1 \text{ cm}^2$
  - d. 4 mm
  - e.  $1 \text{ mm}^3$
  - f.  $3 \text{ km}^2$
  - g. 1 km
  - h.  $3 \text{ cm}^3$
  - i.  $5 \text{ mm}^2$
  - j. 2 cm

- 4.
- a. 15 cm
  - b. 33.2 cm
  - c. 4 m or 400 cm

- 5.
- a.  $7 \text{ m}^2$
  - b.  $12 \text{ m}^2$
  - c.  $15 \text{ m}^2$
  - d.  $16 \text{ m}^2$

6.  $V = lwh$   
 $V = 4 \times 4 \times 6.2$   
 $V = 16 \times 6.2$   
 $V = 99.2$  cubic centimetres or  $99.2 \text{ cm}^3$

### Answer to Lesson 3.2B Practice

1. a. Base = 7 units  
Height = 10 units
- b. Base = 7 units  
Height = 5 units
2. a. 77 units<sup>2</sup>
- b. 20.8 cm<sup>2</sup>
- c. 375 mm<sup>2</sup>
3. a. 3 cm<sup>2</sup>
- b. 3 cm<sup>2</sup>
- c. 72 units<sup>2</sup>
4. 12 m<sup>2</sup>
5. Area depends on dimensions of students' diagram.

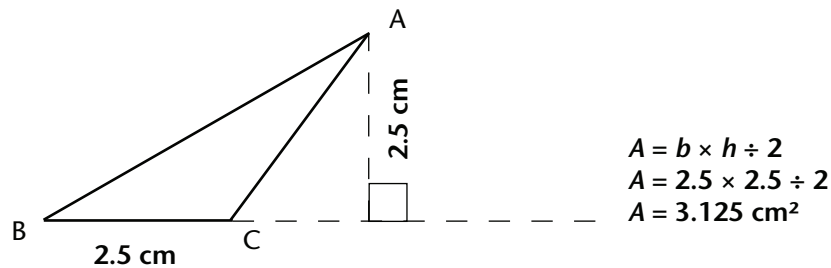

### Answer to Lesson 3.2C Practice

1. *base* = 8 units  
*height* = 8 units  
*Area* =  $b \times h$   
= 8 units  $\times$  8 units  
= 64 units<sup>2</sup>

2. a.  $Area = b \times h$   
 $= 4 \text{ cm} \times 5 \text{ cm}$   
 $= 20 \text{ cm}^2$

b.  $Area = b \times h$   
 $= 8 \text{ units} \times 2 \text{ units}$   
 $= 16 \text{ units}^2$

3. a.  $A = bh$   
 $A = 2 \times 8$   
 $A = 16 \text{ square cm or } 16 \text{ cm}^2$

b.  $A = bh$   
 $A = 4.5 \times 1$   
 $A = 4.5 \text{ square m or } 4.5 \text{ m}^2$

c.  $A = bh$   
 $A = 40 \times 30$   
 $A = 1200 \text{ square cm or } 1200 \text{ cm}^2 \text{ (or } 1.2 \text{ m}^2)$

4.

BASE	HEIGHT	AREA
125 m	25 m	<b>3125 m<sup>2</sup></b>
36 cm	18 cm	<b>648 m<sup>2</sup></b>
10.2 m	8.4 m	<b>86 m<sup>2</sup></b>
0.25 m	4.93 cm	<b>123.3 cm<sup>2</sup></b>
7 cm	<b>7 cm</b>	49 cm <sup>2</sup>
<b>2 m</b>	3.6 m	7.2 m <sup>2</sup>



### Answer to Lesson 3.2D Practice

$$\begin{aligned}
 1. \quad A &= (80 \times 50) - (60 \times 30) \\
 &= 4000 - 1800 \\
 &= 2200 \text{ cm}^2
 \end{aligned}$$

$$\begin{aligned}
 2. \quad A &= (b \times h \div 2) + (l \times w) \\
 &= (12 \times 30 \div 2) + (38 \times 30) \\
 &= 180 + 1140 \\
 &= 1320 \text{ cm}^2
 \end{aligned}$$

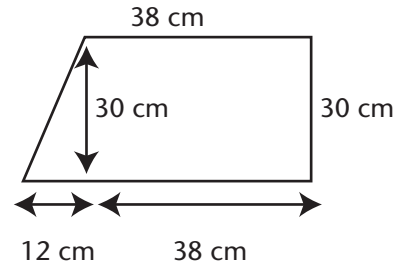

$$3. \quad 300 \text{ cm} = 3 \text{ m}$$

$$A = b \times h$$

$$A = 3 \times 4$$

$$A = 12 \text{ m}^2$$

8 tiles per  $\text{m}^2$

$$8 \times 12 = 96 \text{ tiles}$$

Wendy will use 96 tiles.

$$96 \times \$0.50 = \$48$$

The tiles will cost \$48.

$$4. \quad A = b \times h$$

$$b = A \div h$$

$$b = 4.2 \text{ m}^2 \div 3.5 \text{ m}$$

$$b = 1.2 \text{ m}$$

## Answer to Section Challenge 3.2

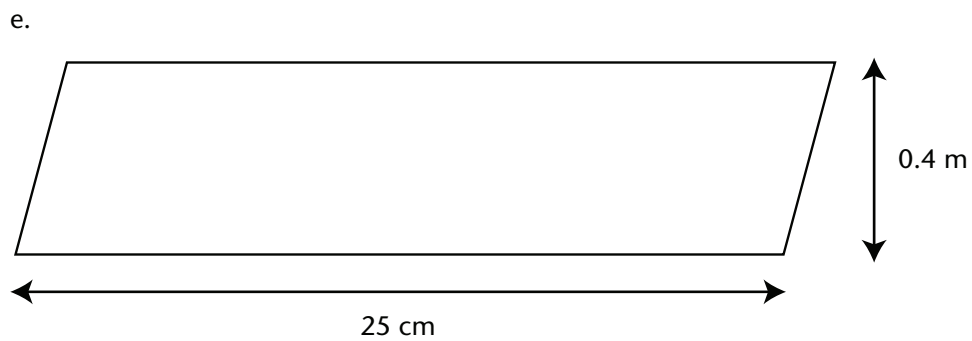
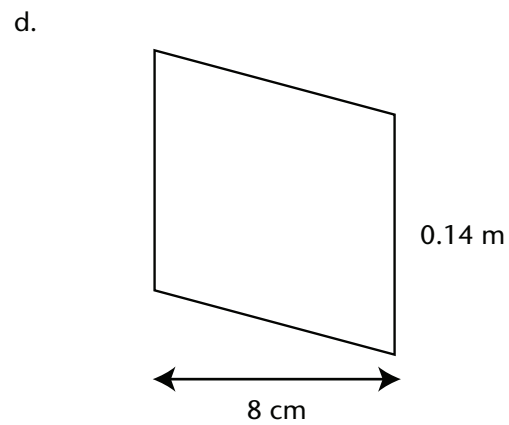
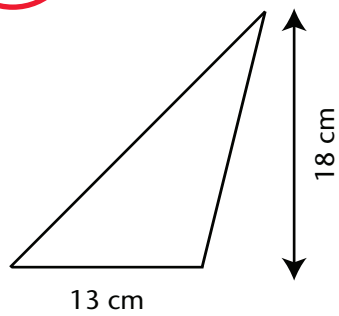
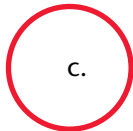
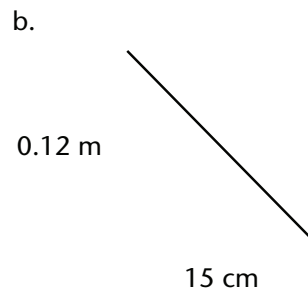
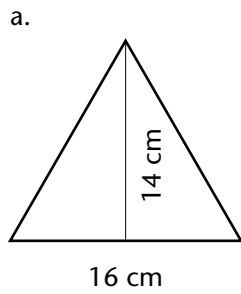

## Answer to Pretest 3.3

- a. centre
- b. diameter
- c. 2
- d. circumference
- e. centre
- f. equal
- g. diameter

2.

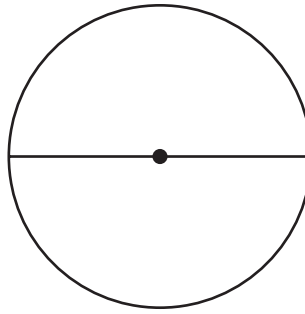

3.

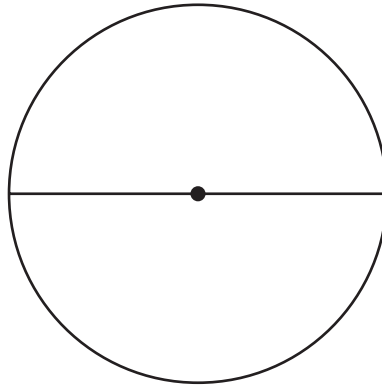

4. a. 6.0 cm

b. 9.2 m

5. a. 2.0 m

b. 6.2 cm

6. a. 31.4 cm

b. 21.0 m

7. a. 31.4 cm

b. 14.4 m

$$\begin{aligned} 8. \text{ Distance} &= \text{Circumference} \times 4 \\ &= (2.0 \times 3.14) \times 4 \\ &= 6.28 \times 4 \\ &= 25.1 \text{ m}^2 \end{aligned}$$

9. a.  $50.2 \text{ cm}^2$

b.  $28.3 \text{ m}^2$

10.  $109.9 \text{ cm}^2$

11.  $157 \text{ m}$

### Answer to Lesson 3.3A Practice

1. a. centre

b. radius

c. radius

d. chord

e. diameter

f. 2

g. circumference

h. centre

i. arc

j. equal

k. diameter

2.

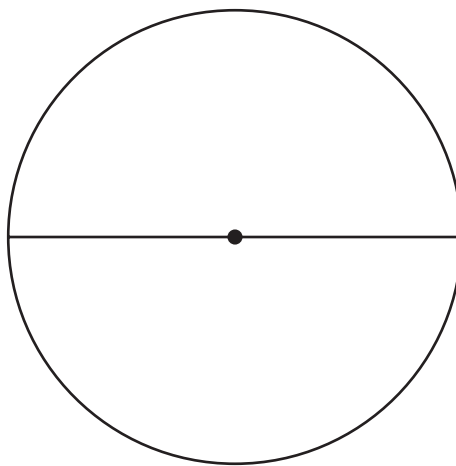

3.

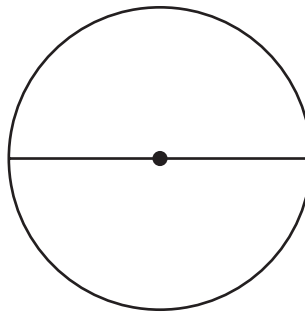

4.

Circle A	$\angle A = \underline{180^\circ}$ $\angle B = \underline{180^\circ}$	$A + B = 360^\circ$
Circle B	$\angle A = \underline{180^\circ}$ $\angle B = \underline{60^\circ}$ $\angle C = \underline{120^\circ}$	$A + B + C = 360^\circ$
Circle C	$\angle A = \underline{90^\circ}$ $\angle B = \underline{90^\circ}$ $\angle C = \underline{140^\circ}$ $\angle D = \underline{40^\circ}$	$A + B + C + D = 360^\circ$

5. a. 22 cm  
 b. 12 cm  
 c. 2.4 cm

6. a. 2.5 cm  
 b. 7 cm  
 c. 3.1 cm

## Answer to Lesson 3.3B Warm-up

1. 4.38

2. 2.57

3. 3.77

4. 6.31

5. 1.71

6. 7.81

7. 5.17

8. 31.55

9. 184.67

10. 4.22

### Answer to Lesson 3.3C Warm-up

1.

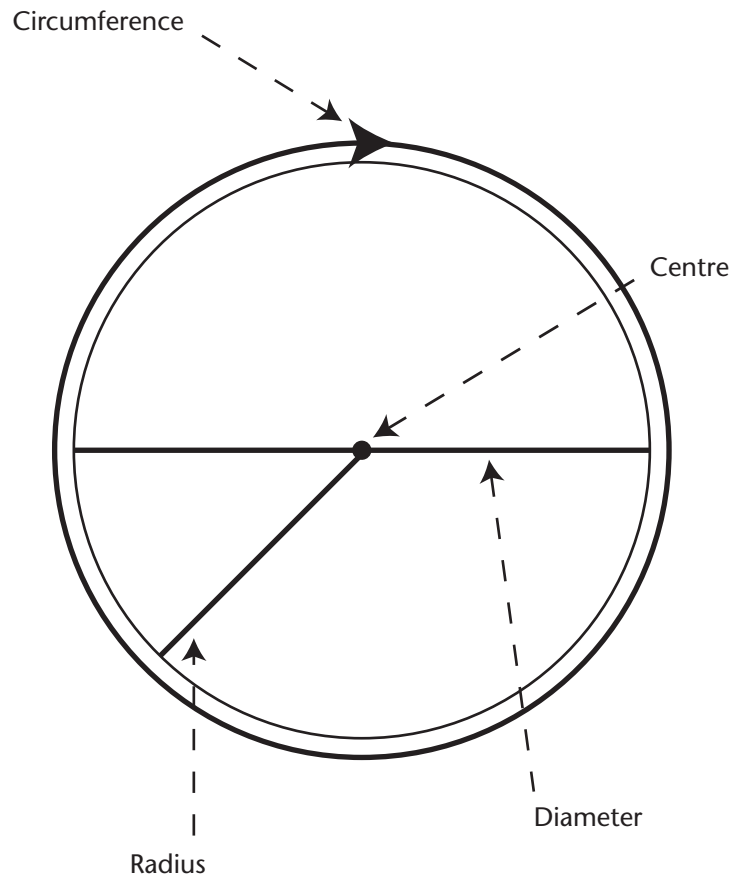

### Answer to Lesson 3.3C Practice

1. a. 9.4 cm  
b. 8.5 cm
  
2. a. 6.0 cm  
b. 9.2 m  
c. 3.8 mm
  
3. a. 2.0 m  
b. 6.2 cm  
c. 4.6 mm

4. a. 31.4 cm  
 b. 21.0 m
5. a. 31.4 cm  
 b. 14.4 m  
 c. 44.0 mm
6. 5 cm
7. 7.6 cm
- 8.

RADIUS	DIAMETER	CIRCUMFERENCE
5.0 cm	<b>10.0 cm</b>	<b>31.4 cm</b>
<b>4.5 cm</b>	<b>9.0 cm</b>	28.3 cm
<b>4.0 m</b>	8.0 m	<b>25.1 m</b>
2.3 mm	4.6 mm	<b>14.4 mm</b>
1.6 cm	<b>3.2 cm</b>	10.0 cm
<b>3.6 m</b>	7.2 m	<b>22.6 m</b>

9. 75.4 cm



### Answer to Lesson 3.3D Practice

- 12.6 cm<sup>2</sup>
  - 16.6 m<sup>2</sup>
- 50.2 m<sup>2</sup>
  - 11.3 cm<sup>2</sup>
- 14 cm
  - 615.4 cm<sup>2</sup>
  - 153.9 cm<sup>2</sup>
- $7.065 \times 2 = 14.1 \text{ m}^2$
- 109.9 cm<sup>2</sup>

### Answer to Section Challenge 3.3

$$\begin{aligned}\text{Area of mirror} &= \pi r^2 \\ &= 3.14(12)^2 \\ &= 314 \times 144 \\ &= 452 \text{ cm}^2\end{aligned}$$

$$\begin{aligned}\text{Area of rim} &= \text{Area of outside circle} - \text{Area of inside circle} \\ &= \pi r^2 - 452 \\ &= (3.14(15)^2) - 452 \\ &= (3.14 \times 225) - 452 \\ &= 706.5 - 452 \\ &= 254.5 \text{ cm}^2\end{aligned}$$



## Module 3 Glossary

### Acute Angle

Measures less than  $90^\circ$ .

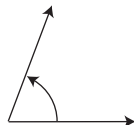

### Acute Triangle

All angles are less than 90 degrees.

### Angle Bisector

A line that cuts an angle in half to form two equal angles.

### Arc

A part of the curve of a circle.

### Area

The amount of surface within a shape. Area is measured in square units.

### Bisector

A line that cuts into two equal parts.

### Central Angle

An angle formed by two radii of a circle.

### Chord

A line segment drawn between two points on the edge of a circle.

### Circumference

Distance around a circle.

### Compass

A tool used to construct circles and arcs.



## Diameter

A line segment drawn from one point on a circle to another point that passes through the centre.

## Equilateral Triangle

Three equal sides and three equal angles.

## Geometry

The study of points, lines, angles, and shapes.

## Intersection Point

The point where two lines cross each other.

## Isosceles Triangle

A triangle with two equal sides and two equal angles.

## Line Segment

A straight line between two points. It has two definite end points and a definite length.

## Obtuse Angle

Measures more than  $90^\circ$  but less than  $180^\circ$ .

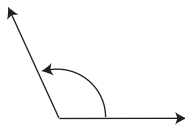

## Obtuse Triangle

Has an angle more than 90 degrees within the triangle.

## Parallel Lines

Two lines that do not intersect.

## Parallelogram

A shape with opposite sides parallel and equal in length.

## Perimeter

Distance around a figure or enclosed area.

## Perpendicular Bisector

A line that intersects a line segment at  $90^\circ$  and divides it into two equal lengths.

### Perpendicular Lines

Lines that meet at a  $90^\circ$  angle.

### Pi ( $\pi$ )

A constant value that is approximately equal to 3.14. It is the ratio of circumference to diameter.

### Polygon

A shape with straight sides.

### Protractor

A tool used to measure angles.

### Radii

Plural form of radius (more than one radius).

### Radius

The length of a line segment drawn from the centre of a circle to a point on the circumference.

### Ray

A straight line that has a beginning point but no end.

### Reflex Angle

Measures more than  $180^\circ$  but less than  $360^\circ$ .

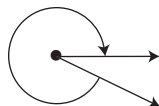

### Right Angle

$90^\circ$  angle.

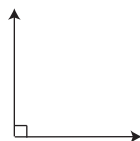

### Right Triangle

Has a  $90^\circ$  angle within the triangle.

### Scalene Triangle

No equal sides and no equal angles.

### Straight Angle

Measures exactly  $180^\circ$ .



### Straightedge

A tool used to draw straight lines.

### Triangle

A shape with three sides and three angles.

### Vertex

The point of intersection where two lines meet to form an angle.

### Volume

The amount of space occupied by a 3-D object; measured in cubic units.